

Service Training



Self-study programme 315

European On-Board Diagnosis

for Diesel Engines

Design and function



On-Board Diagnosis (OBD) systems are required to be installed in diesel passenger cars Europe-wide from 2004 onwards. OBD has been compulsory for petrol-driven vehicles since 2000.

Like the US variant OBD II, the European On-Board Diagnosis (EOBD) features a standardised diagnosis interface, as well as storage and indication of faults relevant to exhaust emissions. EOBD has been adapted to comply with European exhaust emission standards.

Goals of EOBD:

- continuous monitoring of components relevant to exhaust emissions in vehicles
- immediate detection of faults that can lead to an increase in emissions
- indication of faults relevant to exhaust emissions to the driver
- continuously low exhaust emissions in daily vehicle operation



S315_008

NEW



Important Note



This self-study programme shows the design and function of new developments! The contents will not be updated.

For current inspection, adjustment and repair instructions, please refer to the relevant service literature.



Brief overview	4
System overview	12
EOBD routine	14
Scope of testing of EOBD	14
The commencement of injection control deviation	16
BIP control	17
The exhaust gas recirculation position control	18
The exhaust gas recirculation control deviation	19
The glow plug system	20
The CAN data bus diagnosis	21
The charge pressure control deviation	23
The metering adjuster	
The distributor type injection pump	24
Comprehensive Components	
Monitoring	25
The particle filter system	26
The lambda probe heater control	32
The monitoring of individual sensors	33
Service	43
Glossary	55
Explanation of HIGHLIGHTED terms	
Test yourself	56



Brief overview



The history of the EOBD

OBD in the USA

The OBD (On-Board Diagnosis) exhaust emission reduction and diagnosis system became compulsory under law for the first time in the United States of America.

Since 1970, the **California Air Resources Board**, or CARB for short, has been instrumental in reducing air pollution levels through the imposition of statutory requirements. From this evolved the OBD I concept which provided for an OBD system for all vehicles from model year 1991. OBD I was followed by a further directive which prescribed an extension of OBD II for petrol and diesel engines with effect from 1996 and 1997 respectively.

EOBD in Europe

On October 13 1998, the European Union passed an EU directive stipulating the introduction of the European On-Board Diagnosis (EOBD) for all member countries. This directive was incorporated into national law in the Federal Republic of Germany.

New diesel-powered passenger car models will only be eligible for homologation with effect from January 01, 2003 if they are equipped with an EOBD system.

Production diesel-powered passenger cars are required to be equipped with an EOBD system with effect from 2004.

The deadline with regard to new petrol-driven models was January 01, 2000.



For more detailed information on OBD II, please refer to SSP 175, "On-Board Diagnosis System II in the New Beetle (USA)".



For more detailed information on EOBD, please refer to SSP 231, "Euro On-Board Diagnostic System for petrol engines".

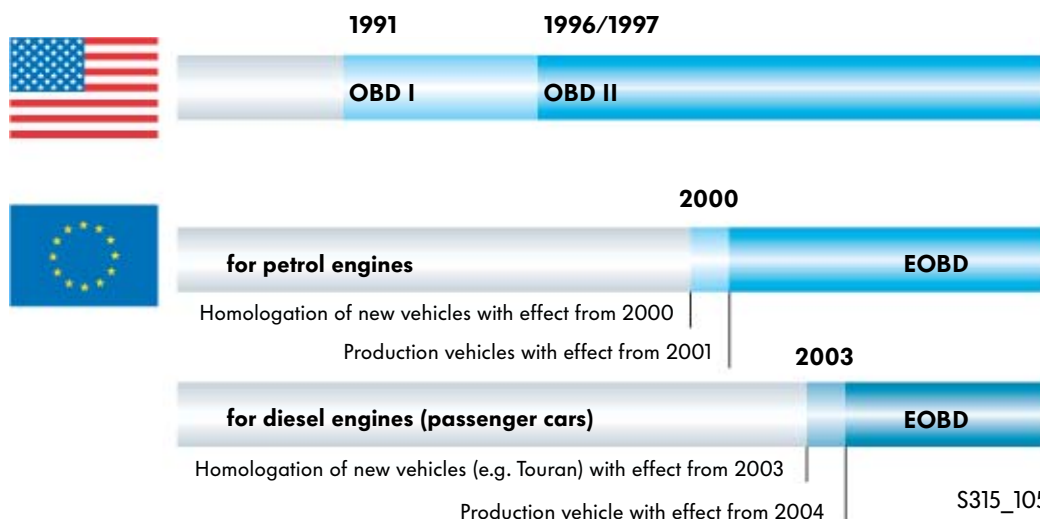

S315_105



What does EOBD involve?

Standardised components

The EOBD checks components, subsystems and electrical components which are relevant to exhaust emissions and, in case of malfunction or failure, can cause defined emission limits to be exceeded.

EOBD is a "lifetime" function. It is required to last for the entire life cycle of a vehicle. The duration of a vehicle life cycle is defined in the EU3 European exhaust emission standard. At this time, EOBD is required to ensure compliance with EOBD exhaust emission limits over a mileage of at least 80,000 km.

When EU4 comes into force in 2005, EOBD must function properly over a mileage of 100,000 km.

In general, the system features:

- a standardised exhaust emissions warning lamp (MIL),
- a standardised diagnosis interface and
- a standardised data protocol.



"MIL" is the abbreviation for "Malfunction Indicator Light". This is the US term for the exhaust emissions warning lamp K83.

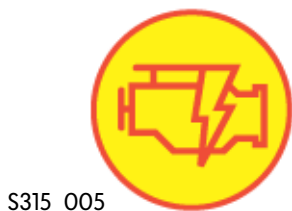

S315_005

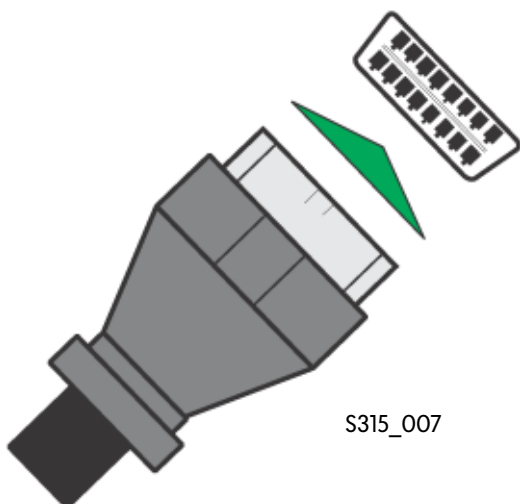

S315_007

The exhaust emissions warning lamp MIL indicates faults that have been diagnosed as being relevant to exhaust emissions by EOBD. When the MIL comes on, the owner must take his or her vehicle immediately to the workshop. A kilometre/mileage counter records how long the vehicle has been driven with the MIL activated.

The standardised diagnosis interface is located in the vehicle interior and must be accessible from the driver's seat.

Brief overview



What does exhaust gas consists of?

The task of EOBD systems is to monitor the serviceability of all in-vehicle systems that are relevant to exhaust emissions.

In the case of the diesel engine, the following pollutants occur in the exhaust gas:

The pollutants arise due to the following influences on the combustion process:

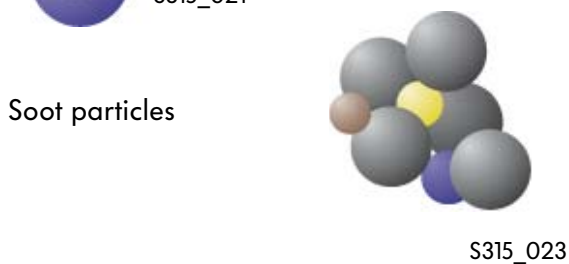
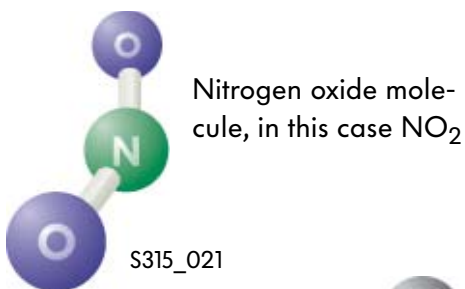
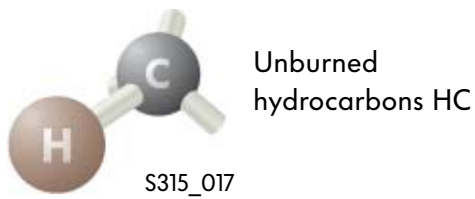
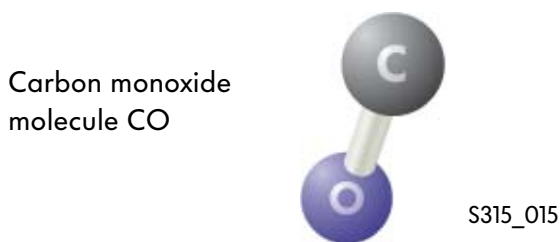

Pollutant	Influences during formation
CO (carbon monoxide)	Form due to the incomplete combustion of combustibles containing carbon.
HC (unburned hydrocarbons)	
SO ₂ (sulphur dioxide)	Forms due to the combustion of fuel containing sulphur.
NO _x (nitrogen oxides)	Form due to high pressure, high temperatures and oxygen surplus during the combustion cycle in the engine.
Soot particles	Consist of carbon which builds up around a condensation core.



For more detailed information on the pollutants, please refer to SSP 230, "Motor Vehicle Exhaust Emissions".



Exhaust emission standards and EOBD

Exhaust emission standards apply in Germany and Europe, in addition to the statutory provisions relating to EOBD.

These standards prescribe exhaust emission limits for the homologation of new vehicle models.

EU3

The EU3 exhaust emission standard has been valid for newly registered vehicles since 2000.

Compared to its predecessor EU2, EU3 specifies more stringent conditions for the rolling road and lower limit values. The previously combined limit for hydrocarbons (HC) and nitrogen oxides (NO_x) will be divided into two separate limit values.

EU3 also requires field monitoring to be carried out. This means that the emission limits must be achieved over a distance of 80,000 km or over a period of 5 years (warranty). This also applies to the functioning of the EOBD system.

EU4

The EU4 standard will come into force in 2005 and will supersede EU3. The consequences are a further reduction in homologation limit values. In addition, warranty will be extended to 100,000 km.

S315_053

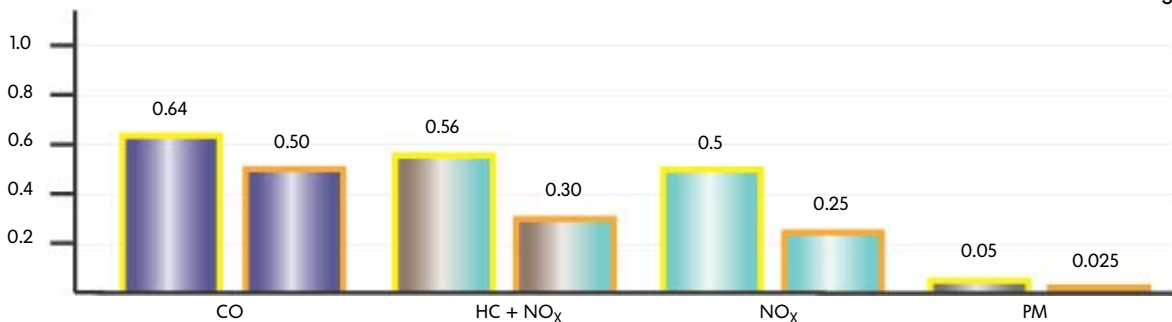

Key:

- permissible emission according to EU3
- permissible emission according to EU4

Brief overview



Timetable of exhaust emission standards

- = with effect from
- = until



EU2 = valid in Europe:



EU3 = valid in Europe:



EU4 = valid in Europe with effect from:

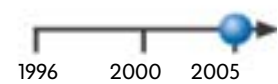

Several of Volkswagen's new diesel engines already meet the stringent EU4 standard, such as the new 2.0l./100kW TDI engine with 4-valve technology.



S315_011

Exhaust emission testing

For homologation, the exhaust emissions of a vehicle are determined on a rolling road using a prescribed measurement system. In the process, a defined driving cycle is run on the rolling road, and the measurement system registers the exhaust gas concentrations. In this way, it is determined whether the emissions of a vehicle are within the limit values established by the relevant standards.

The "New European Driving Cycle" (NEDC) is run to check for pollutant emissions according to EU3 and EU4.

In this context, the EOBD directive requires that all EOBD routines be run within the NEDC.

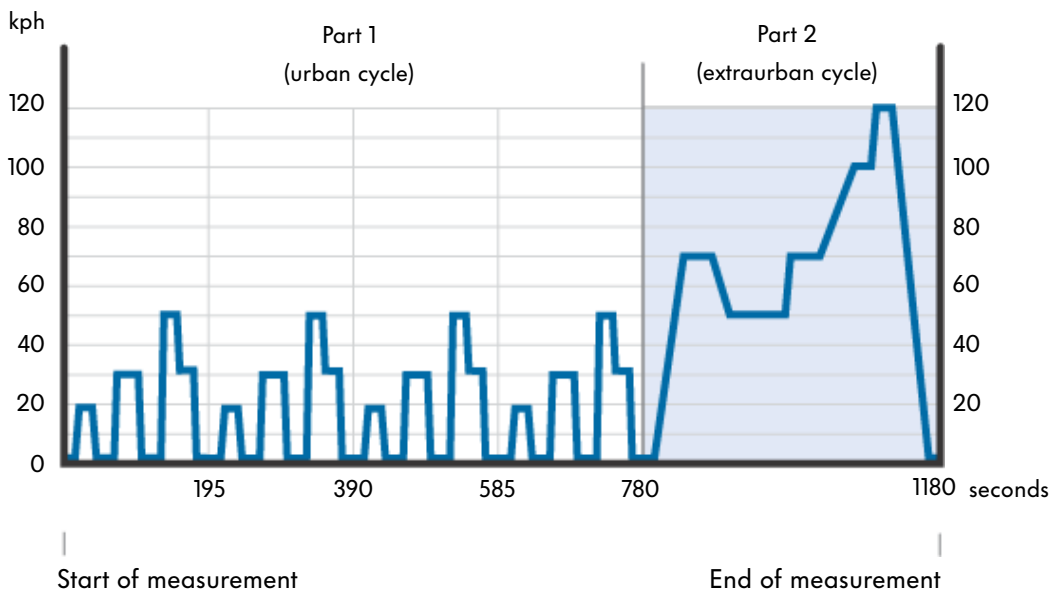

Characteristics

Length of cycle: 11.007 km
Average speed: 33.6 kph
Maximum speed: 120 kph

S315_027



Brief overview



Combustion process in diesel engines

The following diagram shows the combustion process in a 4-stroke diesel engine and a summary of the input and output components for a single combustion cycle.

In the first stroke, air is induced through the air filter. In the process, the constituents of the air - oxygen, nitrogen and water - are transferred to the cylinder chamber.

Intake air:
 O_2 oxygen
 N_2 nitrogen
 H_2O water
(atmospheric humidity)

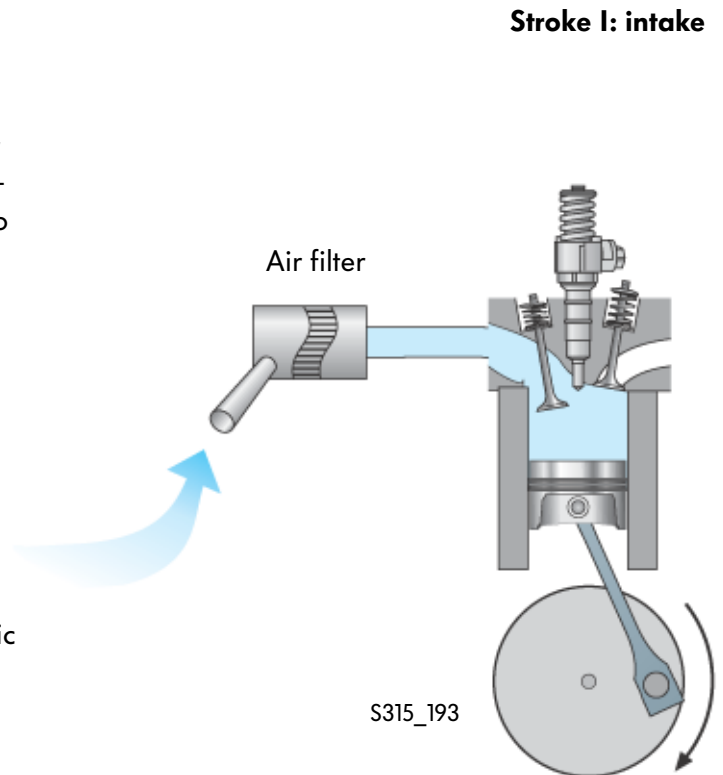

Stroke II: compression

In the second stroke, the intake air is compressed to make subsequent spontaneous ignition possible.

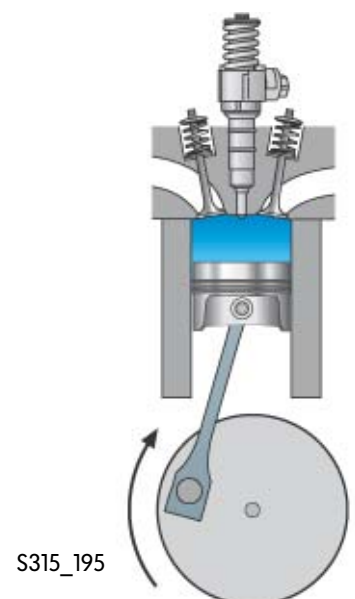



Injected fuel:
 HC hydrocarbons
 S sulphur

**Stroke III: working stroke
 (injection and combustion)**

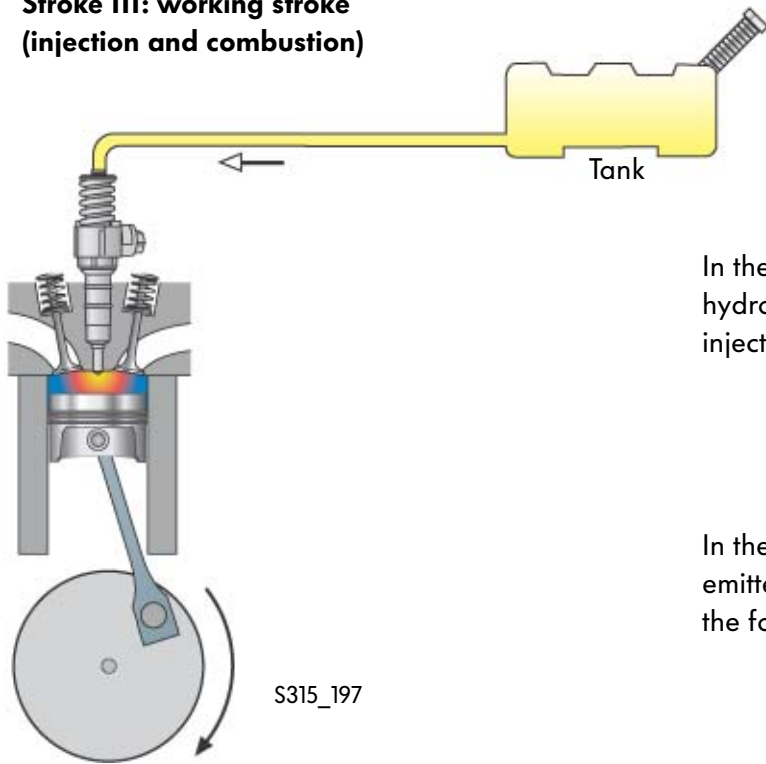

In the third stroke, the fuel consisting of hydrocarbons and sulphur is injected and burned.

In the fourth stroke, the exhaust gases are emitted. The burnt chemical compounds produce the following exhaust gas composition.

S315_197

Stroke IV: emission

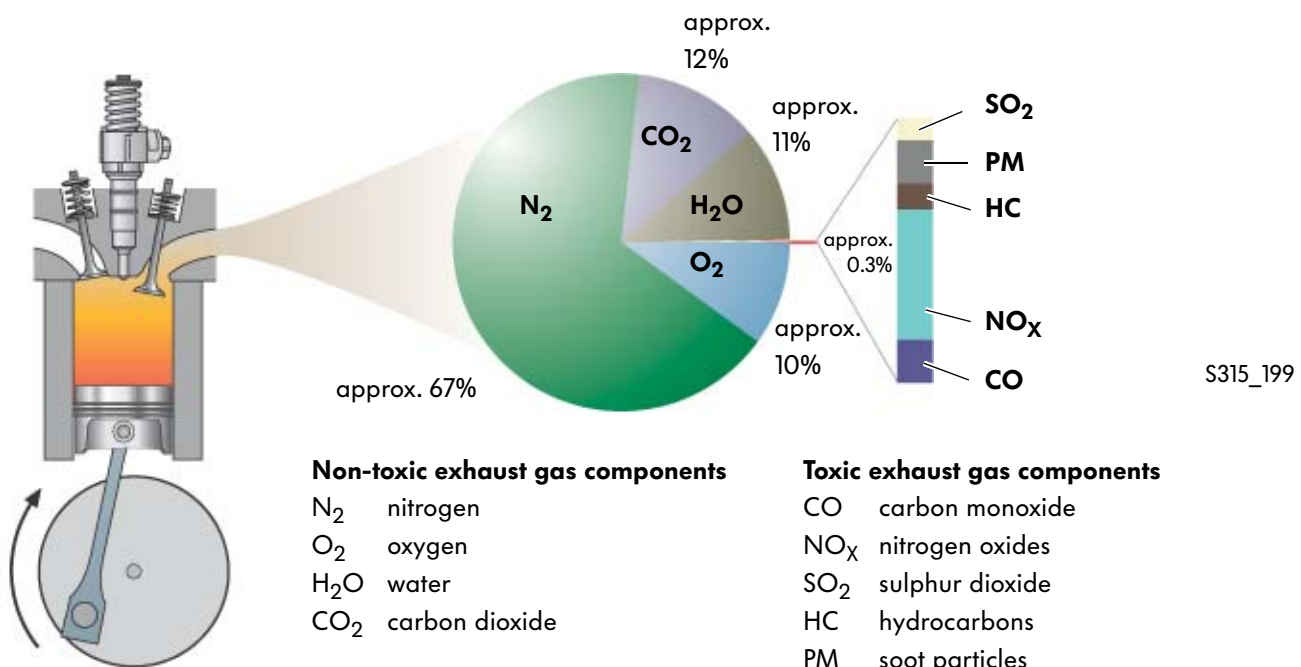

S315_199

System overview

EOBD relevant sensors

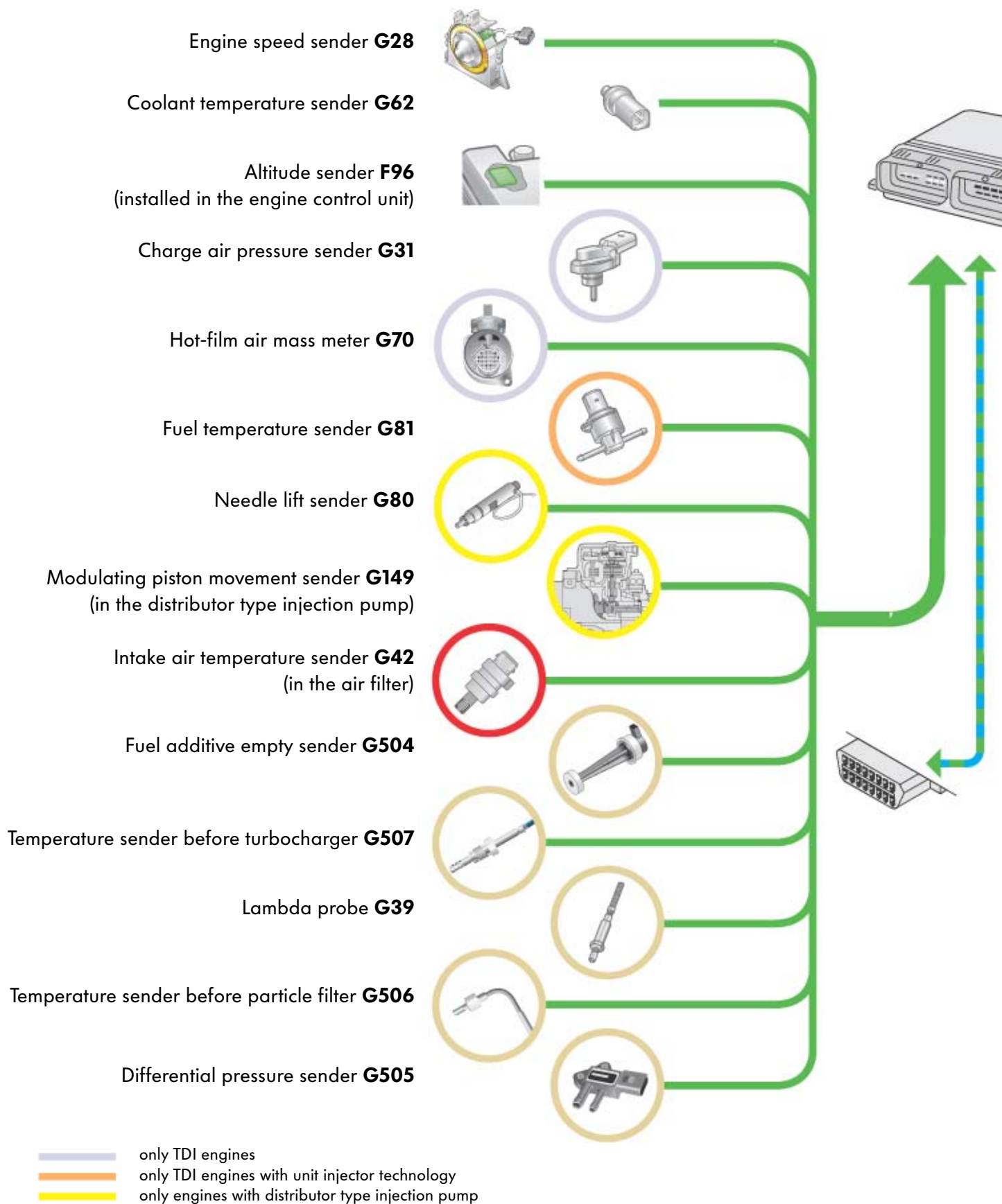

EOBD relevant actuators

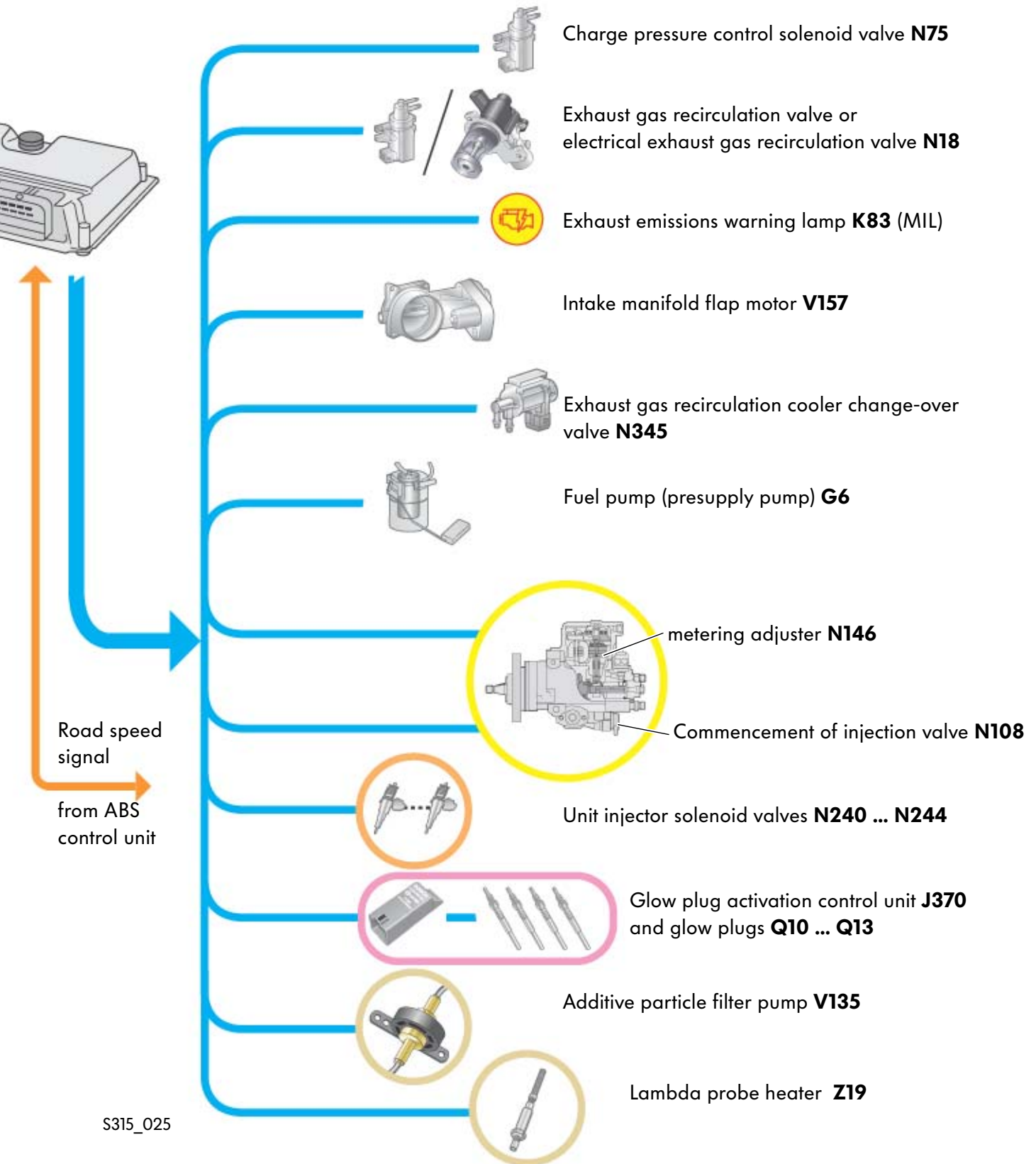

S315_025

- only SDI engines
- only vehicles with particle filter system
- currently only in the Golf with 110 kW diesel engine



EOBD routine

Scope of testing of EOBD

The following list specifies the scope of the EOBD tests for diesels.











Diagnosis method	Engine types		
	SDI with VEP*	TDI with VEP*	TDI with PD**
Commencement of injection control deviation			
BIP control (Begin of Injection Period)			
Exhaust gas recirculation position control			
Exhaust gas recirculation control deviation			
Glow plug system (afterglow phase)			currently only in the Golf with 110 kW diesel
CAN data bus data diagnosis			
Charge pressure control deviation			
Metering adjuster of the distributor type injection pump			
Comprehensive Components Monitoring			
Particle filter monitoring			
Lambda probe heater control			

* VEP= distributor type injection pump

** PD = unit injector technology

Engine types

Sensor plausibilisation	SDI with VEP	TDI with VEP	TDI with PD
Engine speed sender G28			
Coolant temperature sender G31			
Charge air pressure sender G71			
Hot-film air mass meter G70			
Fuel temperature sender G81			
Needle lift sensor G80			
Lambda probe G39			
Road speed signal			

Key

 available in all engines of this type.

 available only in vehicles with particle filter.



EOBD routine

The commencement of injection control deviation

In all **engines with distributor type injection pump**, commencement of injection control is monitored. The commencement of injection affects a large number of engine characteristics, such as starting response, fuel consumption and, not least, exhaust emissions. The task of the injection commencement control is to determine the correct timing for fuel feed.



The engine control unit calculates the correct commencement of injection timing from the following influencing factors:

- engine speed,
- coolant temperature,
- needle lift and
- calculated fuel mass.

Parameters which describe a setpoint range are determined from these values. If the measured actual parameter is out of this range for a certain period of time, this means there is a fault in the commencement of injection control.

Parameters S315_201

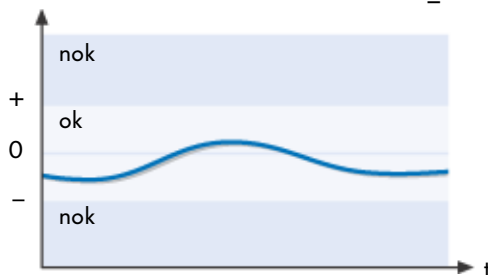

- Commencement of injection control deviation ok
If the measured control deviation stays within the setpoint range, no fault is registered.

Parameters S315_203

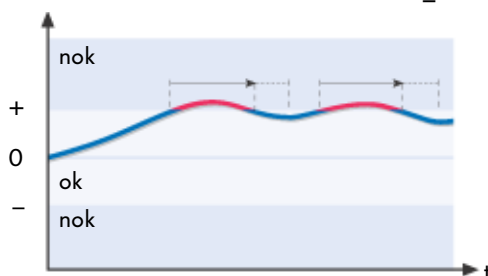

- Commencement of injection control deviation ok
Likewise, no fault is indicated if the measured control deviation runs out of the setpoint range for a short time.

Parameters S315_147

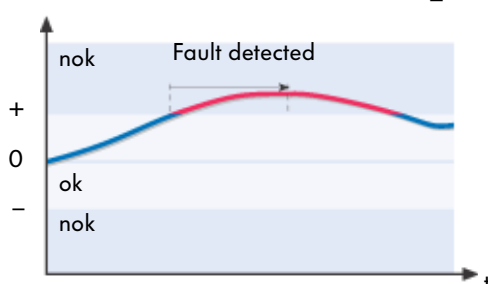

- Commencement of injection control deviation not ok (nok)
A fault is only registered if the measured control deviation stays above or below the setpoint range for a certain period.

BIP (Begin of Injection Period) control

In all **TDI engines with unit injector system**, the injection cycle is monitored by means of BIP control. In the process, the engine control unit monitors the current curve of the unit injector valve. From this information, the unit injector valve obtains feedback on the actual commencement of injection and can detect malfunctioning in the valve.

The BIP of the unit injector valve is identifiable by a noticeable kink in the current curve. If the BIP is within the control limit, the valve is intact. If it is outside the control limit, the valve is defective. A fault is registered and the MIL is activated.



"BIP" stands for "Begin of Injection Period".

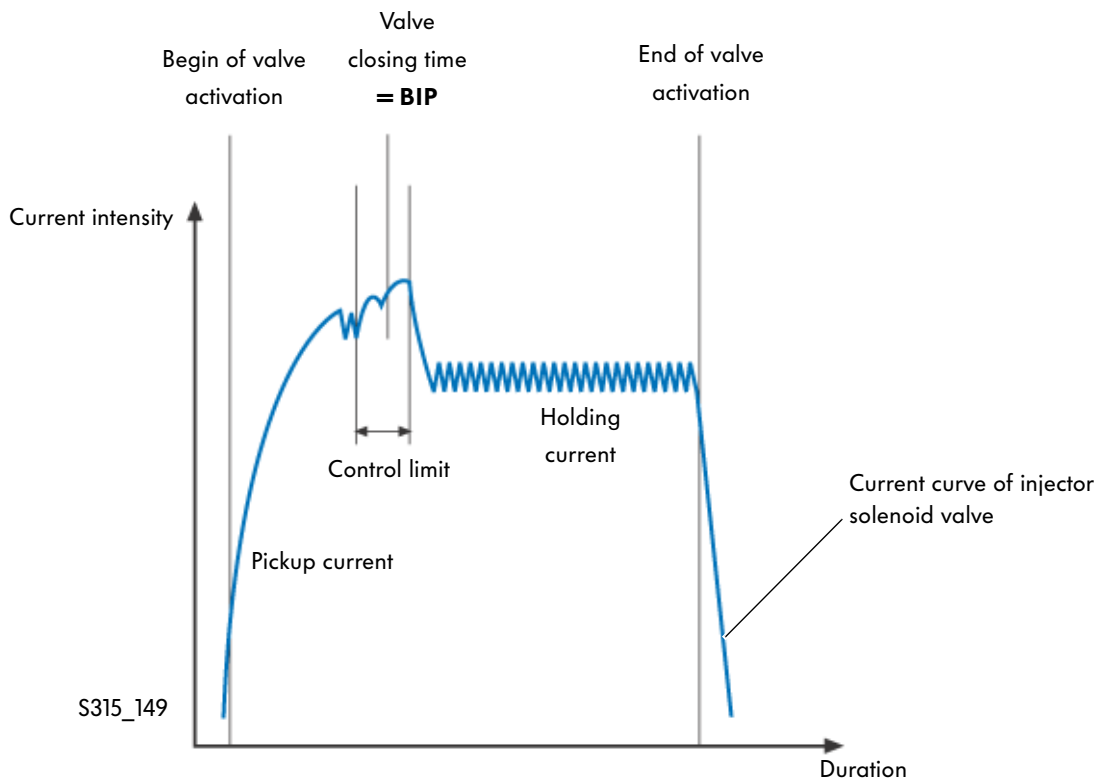

For more detailed information on unit injector systems and BIP, please refer to SSP 209, "1.9l TDI engine with unit injection system".



EOBD routine

The exhaust gas recirculation position control

An electronically actuated exhaust gas recirculation valve (EGR valve) which allows faster adjustment of the required EGR rate is used in new **engines with particle filter system**. This new technology permits detection of any valve position.

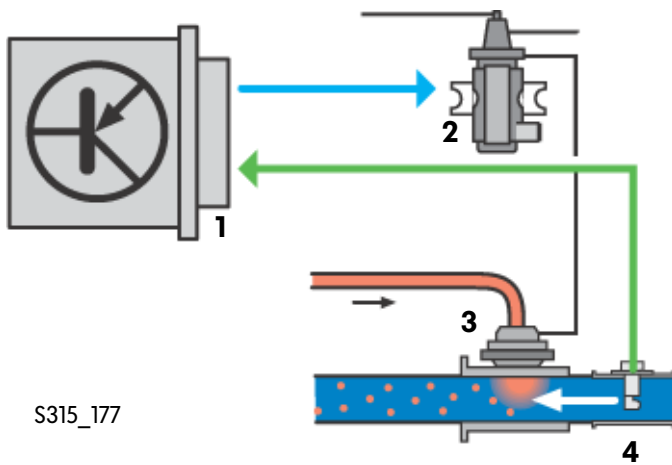

S315_177

In the case of the pneumatically activated EGR valve, the hot-film air mass meter is used to determine whether the EGR valve is defective. Here the exhaust gas recirculation control deviation is used as a reference. The drawback of this system is its relatively long reaction time.

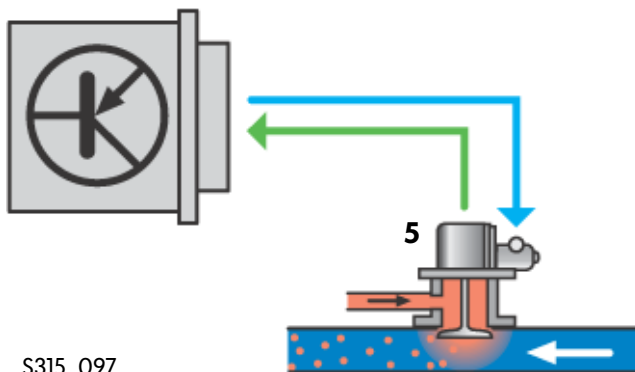

S315_097

Exhaust gas recirculation position control is possible with the electrical EGR valve; a valve position sensor mounted on the shaft of the EGR valve detects the position of the valve and indicates this to the engine control unit. This accelerates the reaction time of the EGR control.

- 1 Engine control unit
- 2 Exhaust gas recirculation valve N18
- 3 EGR valve
- 4 Hot-film air mass meter G70
- 5 Electrical exhaust gas recirculation valve with position feedback N18

The exhaust gas recirculation control deviation

In all **TDI engines**, an air-mass tolerance window is determined from the following data for the exhaust gas recirculation control diagnosis:

- speed (signal from engine speed sender),
- setpoint air mass and
- injection quantity.

Parameters which describe a setpoint range are determined from these three values.

If the measured actual air mass is out of this range over a certain period, this means there is a fault in the EGR system.



Parameters

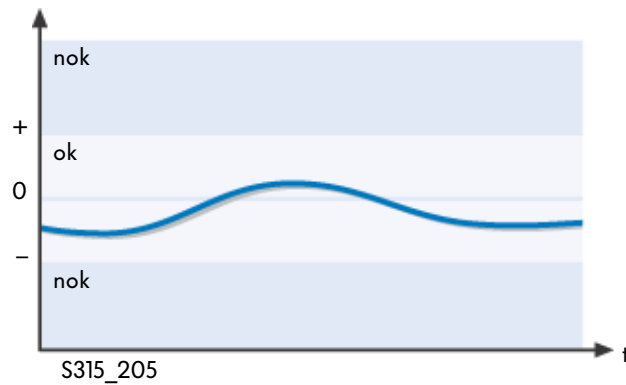

- EGR control deviation ok
If the measured control deviation stays within the setpoint range, no fault is registered.

Parameters

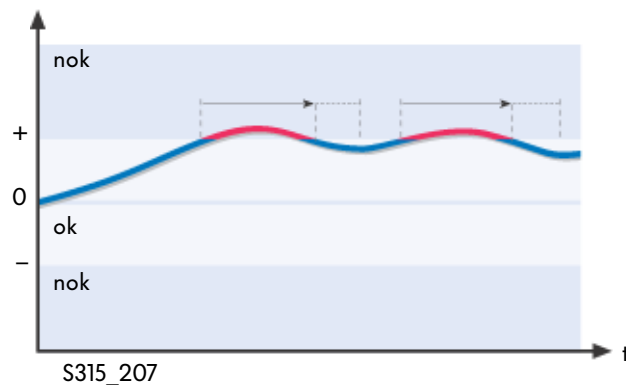

- EGR control deviation ok
Likewise, no fault is indicated if the measured control deviation runs out of the setpoint range for a short time.

Parameters

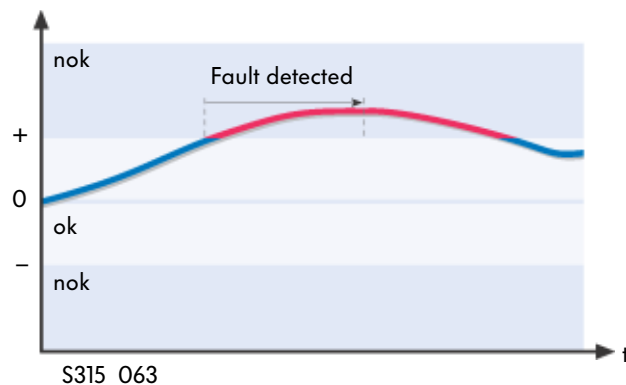

- EGR control deviation nok
A fault is only registered if the measured control deviation stays above or below the setpoint range for a certain period.

EOBD routine

Glow plug system

There are various glow stages. The pre-glow phase improves the cold-starting characteristics of the engine. In the diesel engine, the after-glow phase serves principally to heat up the combustion chamber more quickly. In the current **Golf with 110 kW diesel engine**, the glow plug continues to glow even at a coolant temperature of over 20°C. This serves to reduce exhaust emissions and is therefore relevant to EOBD.

A separate glow plug activation control unit is used for this after-glow phase, which is relevant to exhaust emissions. This glow plug activation control unit can be activated by a glow request from the engine control unit. The glow plug activation control unit then sends a diagnosis log back to the engine control unit. With this log, the glow plug activation control unit signals detected faults (short circuit and open circuit) to the engine control unit.

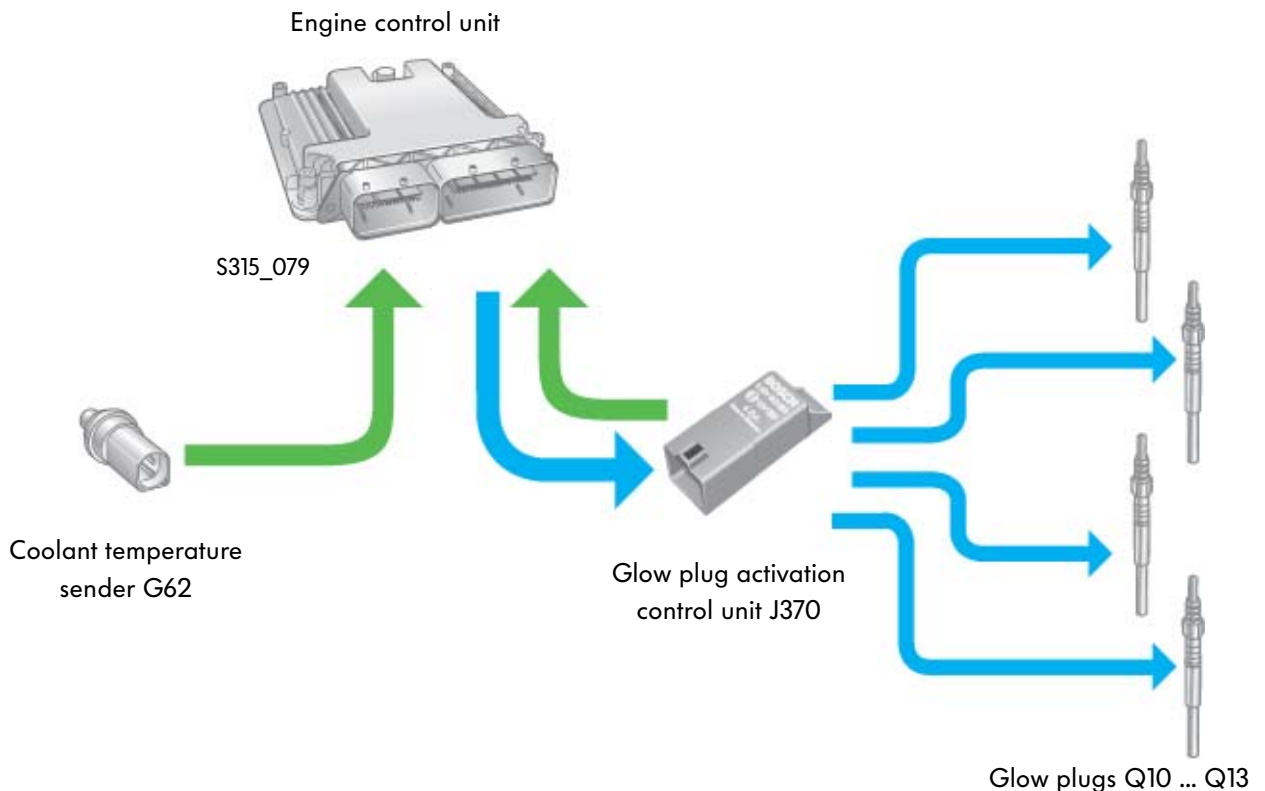

The CAN data bus diagnosis

Each engine control unit knows the EOBD relevant control units, which exchange information on the CAN data bus in each vehicle. If the expected message from a control unit is not received, a fault is detected and stored.

EOBD relevant control units which utilise the CAN data bus include:

- control unit with display in dash panel insert,
- ABS/ESP control unit,
- automatic gearbox control unit.

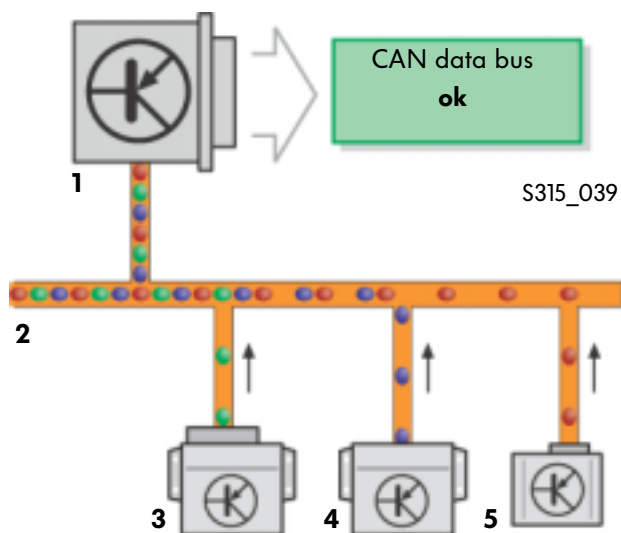

- 1 Engine control unit
- 2 CAN data bus
- 3-5 Various inboard control units

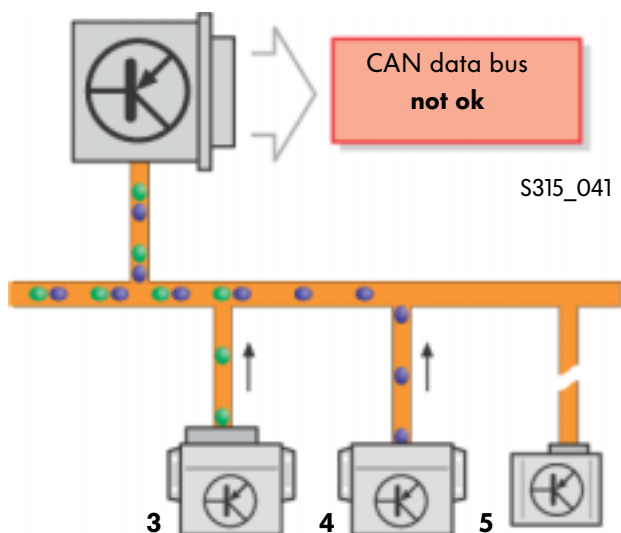

- CAN data bus operational
All connected control units regularly send messages to the engine control unit. The engine control unit establishes that no message is missing and that data exchange is being carried out correctly.

- CAN data bus interrupted
A control unit cannot send any information to the engine control unit. The engine control unit notices the missing information, identifies the control unit in question and registers the fault.

EOBD routine

For EOBD it is important that the CAN data exchange functions smoothly, because the so-called "MIL requests" from other control units are sent via CAN bus.

MIL requests are instructions to activate the exhaust emissions warning lamp MIL.

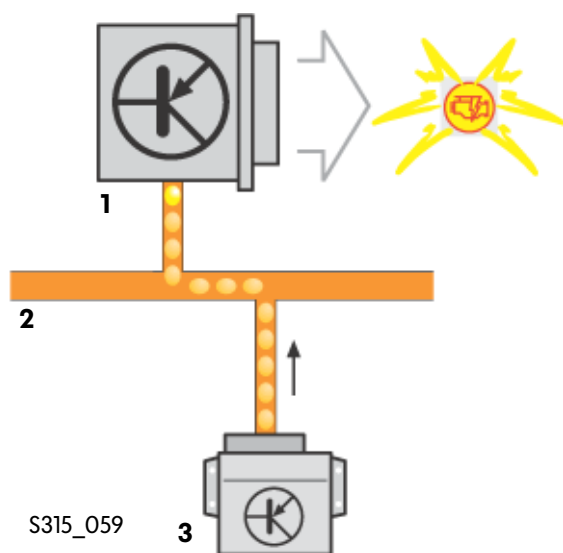

If, for example, the gearbox control unit detects a fault in the gearbox, it sends an MIL request to the engine control unit via CAN data bus. The MIL must be activated, because a fault in the gearbox may also be relevant to exhaust emissions.

- 1 Engine control unit
- 2 CAN data bus
- 3 Gearbox control unit

The charge pressure control deviation

Monitoring for charge pressure control deviation is carried out in **TDI engines**. It is only possible at certain operating points. These operating points are defined as a function of engine speed and injection quantity.

If the control deviation is out of the permissible range for a certain period, this means there is a fault in the charge pressure system.



Parameters

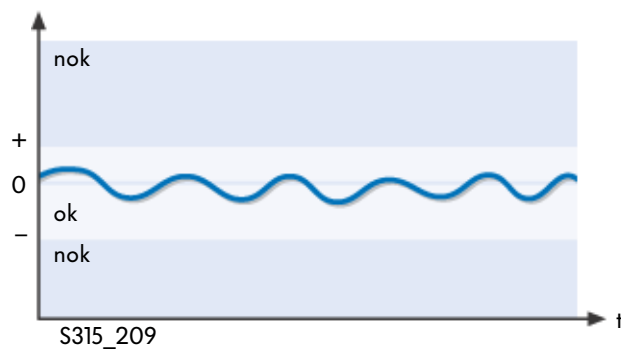

- Charge pressure control deviation ok
If the control deviation stays within the setpoint range, no fault is registered and the MIL stays off.

Parameters

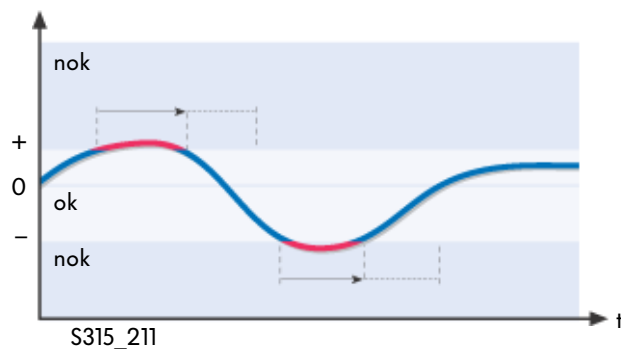

- Charge pressure control deviation ok
Likewise, no fault is indicated if the control deviation runs out of the setpoint range for a short time.

Parameters

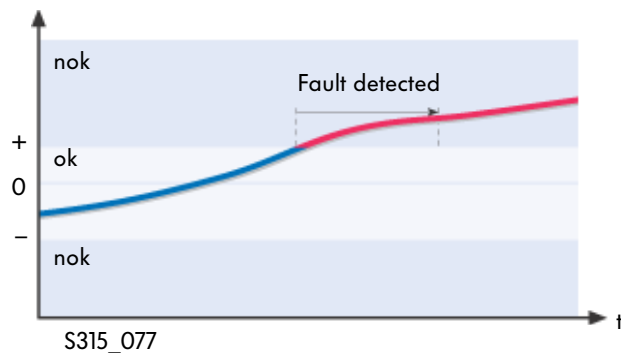

- Charge pressure control deviation nok
A fault is registered and the MIL comes on only if the control deviation stays above or below the setpoint range for a certain period.

EOBD routine

The metering adjuster of the distributor type injection pump

The metering adjuster consists of the following components:

- modulating piston movement sender G149,
- fuel temperature sender G81 and
- metering adjuster N146.

EOBD checks the electrical function of the modulating piston movement sender and fuel temperature sender, as well as the upper and lower stops of the metering adjuster.

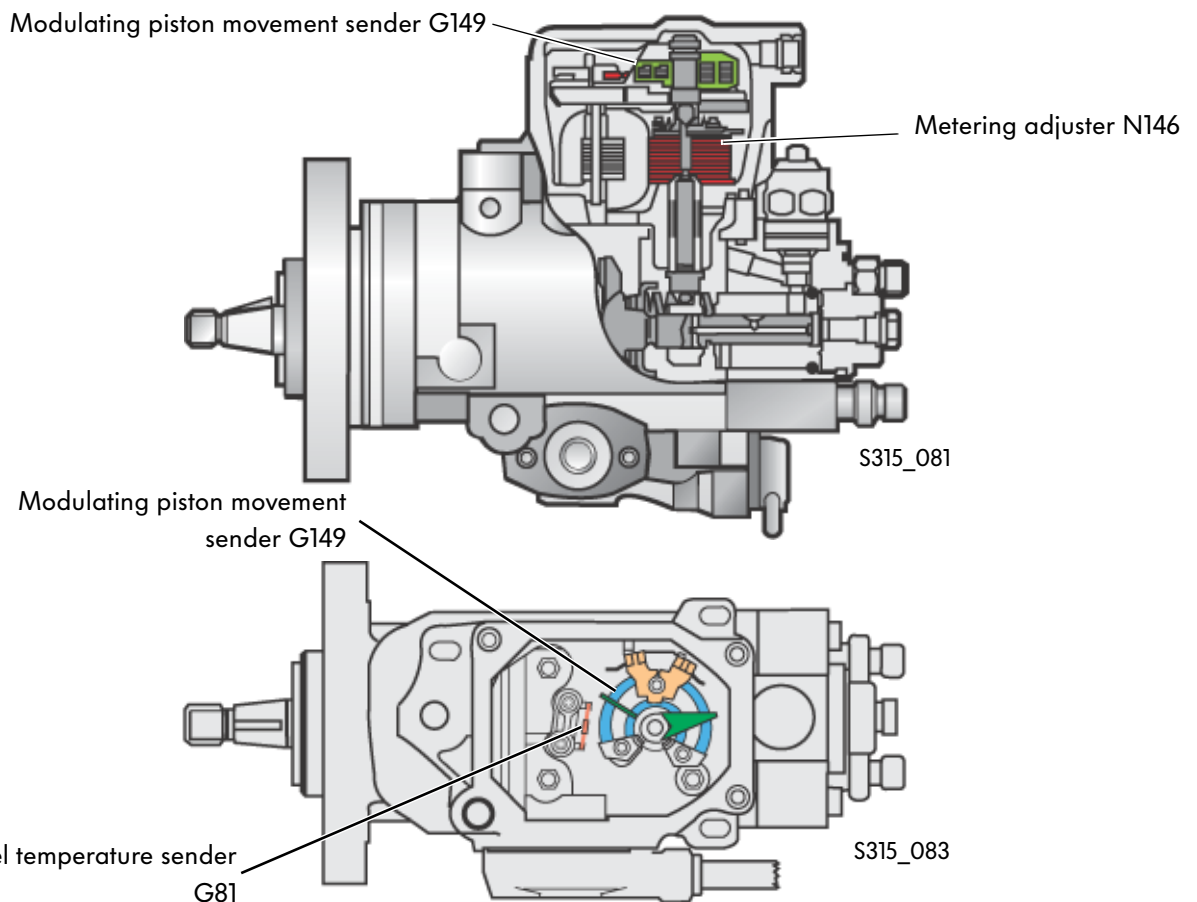

Comprehensive Components Monitoring

This diagnosis method monitors the electrical functioning of all sensors, actuators and the output stages of other components relevant to exhaust emissions within the context of the EOBD. At the same time, each control unit monitors the connected sensors, actuators and output stages on the basis of the ascertained voltage drop.

In the function diagrams you can see what components are monitored for each vehicle.

In the framework of Comprehensive Components Monitoring, components are checked for:

- faulty input and output signals,
- short circuit to earth,
- short circuit to positive and
- open circuit.



EOBD routine

The particle filter system

Volkswagen has achieved the stringent EU4 exhaust emission standards, e.g. in the 2.0l diesel engine in the Golf, by making improvements to the combustion characteristic and by employing higher injection pressures (unit injector).

If, however, the same engine is installed in a heavier vehicle, such as the Passat, the exhaust emission levels will be higher in certain load states. This behaviour is typical of diesel engines. This has prompted Volkswagen to deploy a particle filter system.

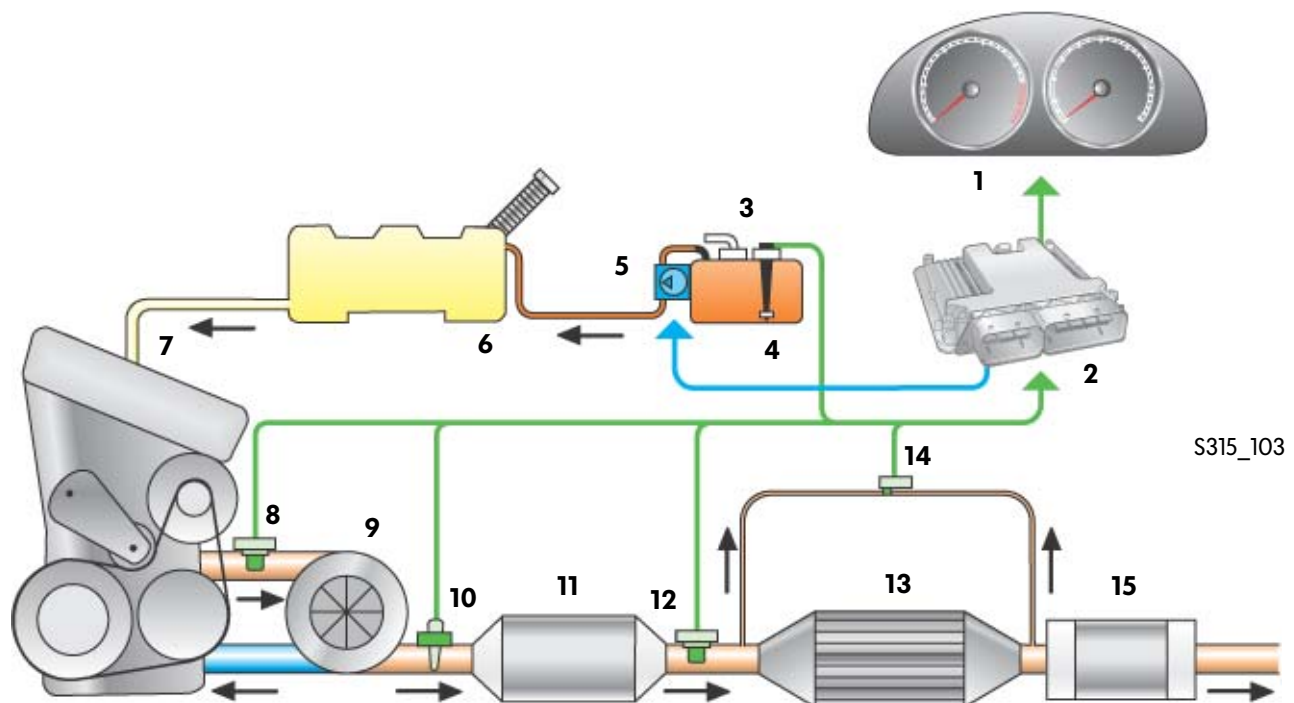

S315_103

- | | |
|-------------------------------------------------------|---------------------------------------------------|
| 1 Control unit with display in dash panel insert J285 | 8 Temperature sender before turbocharger G507 |
| 2 Engine control unit | 9 Turbocharger |
| 3 Additive tank | 10 Lambda probe G39 |
| 4 Fuel additive empty sender G504 | 11 Oxidation catalytic converter |
| 5 Additive particle filter pump V135 | 12 Temperature sender before particle filter G506 |
| 6 Fuel tank | 13 Particle filter |
| 7 Diesel engine | 14 Differential pressure sender G505 |
| | 15 Silencer |

The fuel system

For the particle filter system, an additive tank (3) with a fuel additive empty sender (4) and an additive particle filter pump (5) have been added to the fuel system used in the diesel engine. The additive is required for regeneration of the particle filter.

For refueling, the additive particle filter pump is activated by the engine control unit, and a small, proportionate amount of additive is pumped into the fuel tank for mixing. A single additive tank filling is sufficient to cover a distance of approx. 100,000 km.



The exhaust system

In the case of the exhaust system, two temperature senders (8) and (12), a lambda probe (10), a particle filter (13) and a differential pressure sender (14) have been added.

The control unit detects increasing clogging of the particle filter from the information supplied by the differential pressure sender (14), i.e. rising exhaust gas pressure before the particle filter. If the filter is becoming clogged, the soot residues must be burned. To regenerate the particle filter, the engine control unit initiates a post-injection cycle which does not affect torque. In the process, two control values are evaluated: the lambda value and the required exhaust gas temperature. The actual exhaust gas temperature is determined by the temperature senders.

EOBD monitoring of the particle filter

The following particle filter components are tested for correct electrical function:

- fuel additive empty sender G504
- additive particle filter pump V135,
- temperature sender before turbocharger G507,
- lambda probe G39,
- temperature sender before particle filter G506 and
- differential pressure sender G505.

EOBD routine

The particle filter

The particle filter is installed behind the catalytic converter and filters soot particles almost completely out of the exhaust gases.

The particle filter has parallel ducts made from silicon carbide, which are alternately closed. The exhaust gas flows through the filter. The soot particles are retained in the input channels, while the gaseous exhaust gas constituents are able to diffuse through the porous walls.

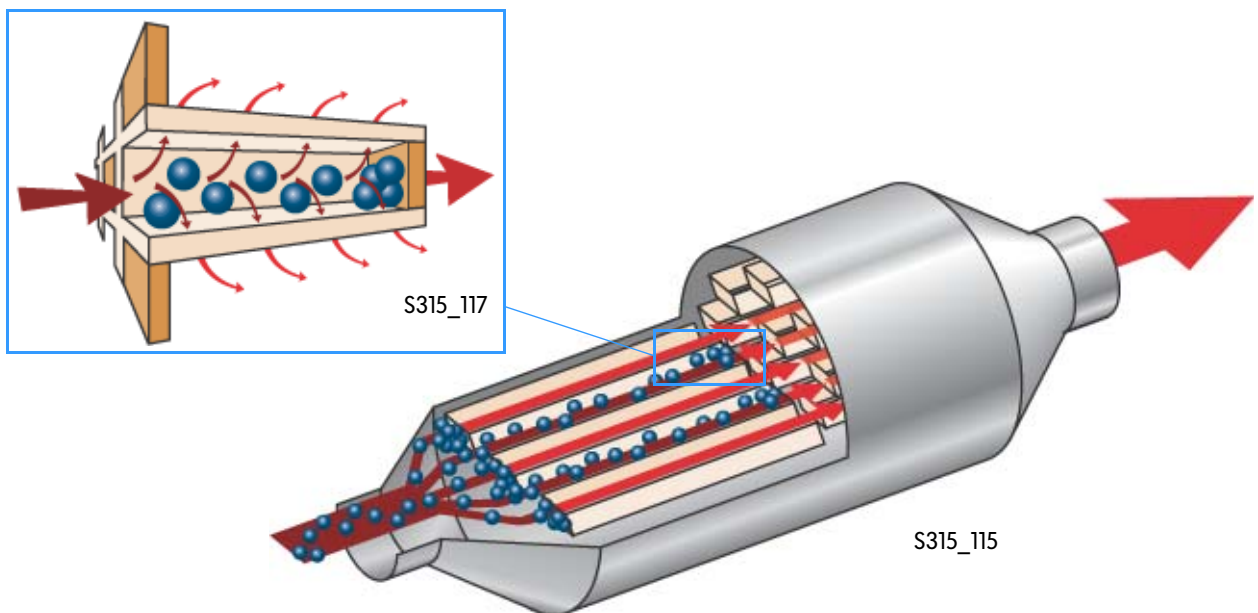

The properties of silicon carbide (SiC)

SiC, the material from which the soot particle filter is made, is a high-performance ceramic used in a number of technical applications. The material has the following outstanding properties:

- high to very high strength,
- excellent resistance to thermal shocks,
- low thermal expansion,
- high wear resistance.

Regeneration of the particle filter

The exhaust gas filtering process is unproblematic. If, however, soot particles collect in the filter, this will increase the flow resistance. A differential pressure sender is used to determine the pressure differential between the filter inlet and outlet. If the pressure difference is too large, this is an indication that the filter is becoming clogged.

This can cause the filter and engine to malfunction. In this case, the filter must be regenerated by burning off the soot residues.

However, the ignition temperature of soot is approximately 600- 650°C - an exhaust gas temperature which a diesel can only achieve at full throttle. To be able to carry out regeneration of the filter in other operating states, the ignition temperature of the soot has to be reduced by adding an additive, and the exhaust gas temperature has to be increased through selective engine management.

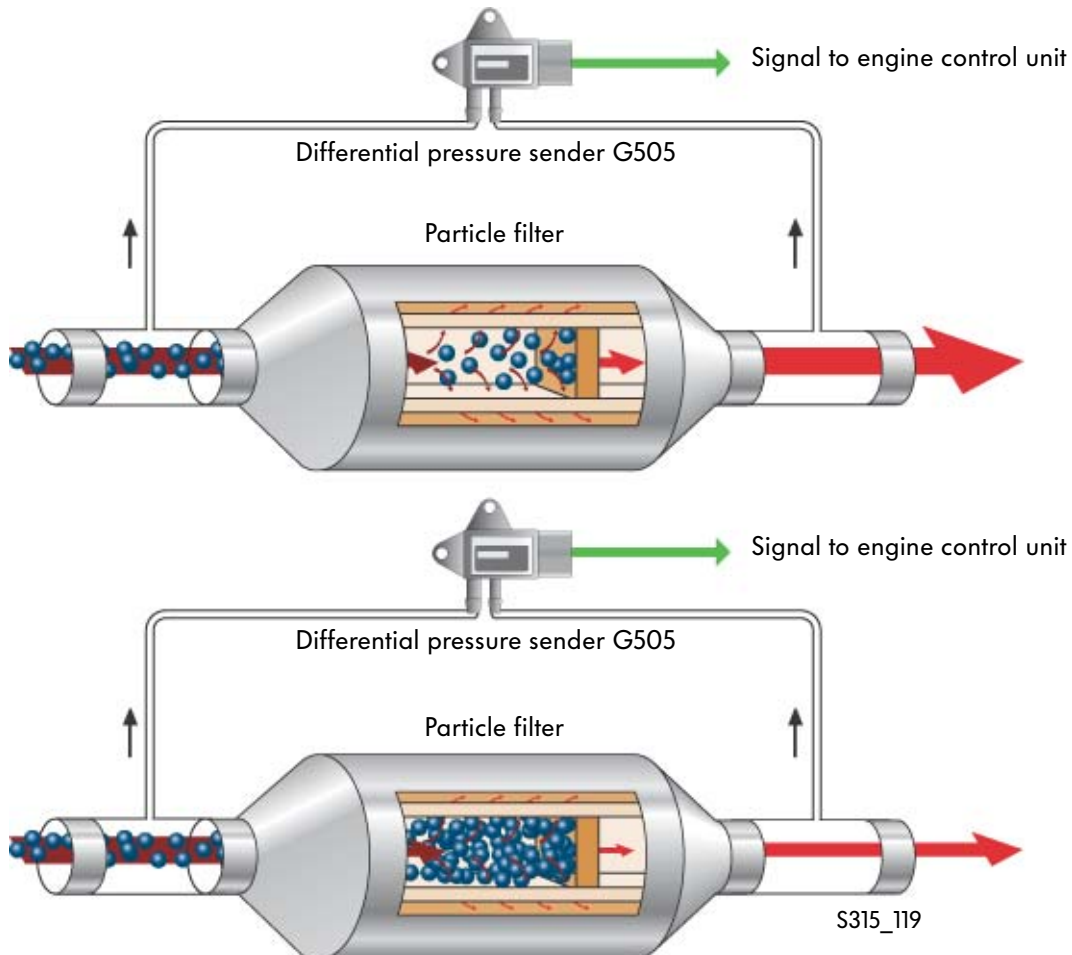

EOBD routine

Addition of an additive

The additive is located in a separate tank and is added to the fuel during refueling. It contains an organic iron compound. This reduces the ignition temperature of the soot to approx. 500°C.



The filter is unsuitable for biodiesel (rapeseed methyl ester fuels).

Controlled engine management

For regeneration of the particle filter, the thermodynamic efficiency of the engine is reduced such that the exhaust gas temperature is raised to at least 500°C without affecting torque. This is basically achieved by deactivating the exhaust gas recirculation system, increasing the charge pressure and restricting the fresh air supply with the throttle valve. At the same time, the fine tuning of these intervention measures is dependent on the operating state of the vehicle. After the main fuel injection has been reduced, additional fuel is injected when the piston is clearly past TDC during the working stroke. The complete engine intervention cycle is performed every 500 - 700 kilometres depending on driving mode, and takes roughly 5 - 10 minutes.

General information on the particle filter system

The additional injection cycle increases the fuel consumption of vehicles with a particle filter system by 1 - 2%. In addition, increased exhaust emissions can occur during an emission test when the regeneration cycle is initiated.

Not only SOOT but also ASH is collected in the particle filter. This ASH cannot be burned and will eventually reduce the effective capacity of the filter.

For this reason, the particle filter must be cleaned of ASH or replaced every 120,000 km.

The additive must be changed after 120,000 km or 4 years. This is necessary because sediments that can damage the particle filter system can form in the additive after the expiry date (approx. 4 years).

If there is no longer sufficient additive in the additive tank, this is indicated by the "engine fault workshop" lamp.

Regeneration of the particle filter can be impaired if the vehicle is operated over short distances for a lengthy period.

In this case, a particle filter system warning lamp will come on. It refers the customer to the relevant vehicle literature which explains how regeneration can be assisted by driving in the appropriate way.

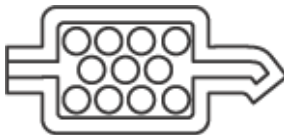

S315_221

The new particle filter warning lamp in the dash panel insert is shown on the left.



The differential pressure sender G505

The differential pressure sender is designed such that it measures the pressure difference in the exhaust gas flows before and after the particle filter.



S315_139

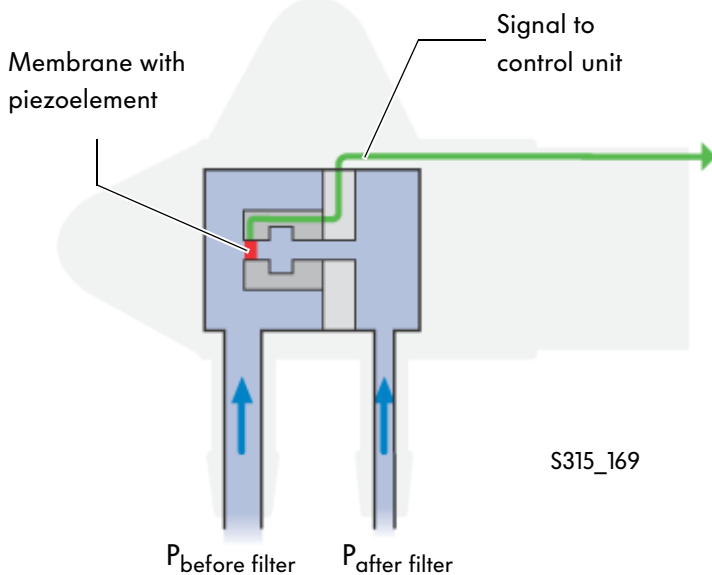

S315_169

This is how it works:

Pressure lines branch to the differential pressure sender from the exhaust gas stream before the particle filter and from the exhaust gas stream after the particle filter. In the differential pressure sender, there is a membrane with piezoelements upon which the exhaust gas pressures $P_{\text{before filter}}$ and $P_{\text{after filter}}$ act.

EObD routine

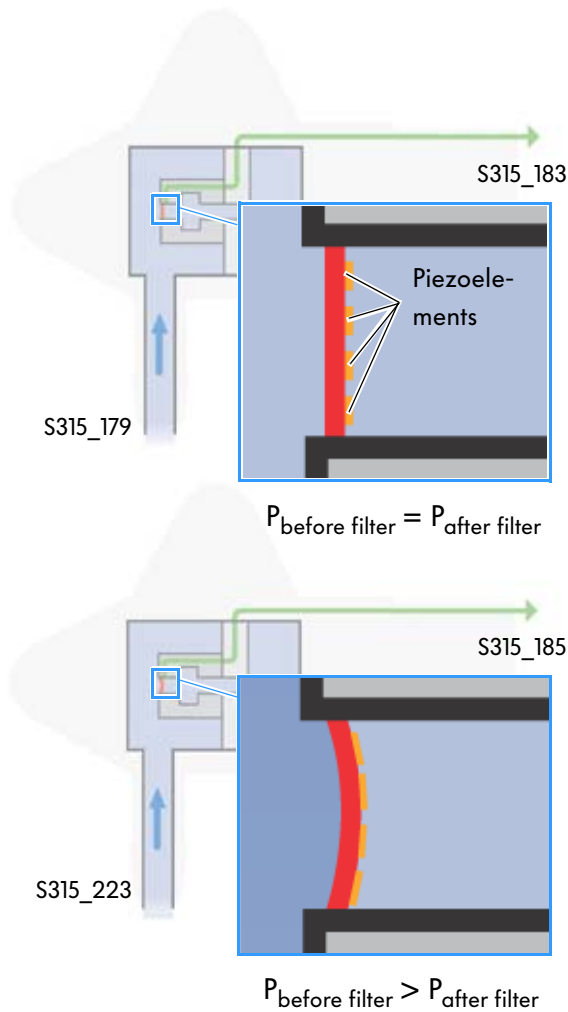

In an unobstructed particle filter, the pressure before and after the filter is almost identical. The membrane with the piezoelements is in a position of rest.

The exhaust gas pressure before the particle filter rises, because the volumetric flow rate is reduced by soot buildup in the filter. The exhaust gas pressure behind the particle filter remains almost constant, with the result that the membrane with the piezoelements deforms according to the pressure. This deformation alters the electrical resistance of the piezoelements which are connected to form a measuring bridge. The output voltage of this measuring bridge is conditioned by the sensor electronics, amplified and provided to the engine control unit as a signal voltage. The engine control unit then initiates a secondary combustion cycle for cleaning the particle filter.

The lambda probe heater control

In addition to the electrical function of the components in the particle filter system, the lambda probe heater control is monitored separately.

To this effect, the measured value of the internal lambda probe temperature sensor is compared to the temperature of the standard operating point. If the temperature deviation in relation to the standard operating point (e.g. 780°C) is too large, the engine control unit registers a fault relevant to exhaust emissions and the MIL is activated.

Monitoring of individual sensors

Individual sensors are generally monitored for three types of fault:

- Are the measured values of the sensor plausible?
If a specific fault has occurred in a particular component, the sensor may indicate a measured value which does not correspond to the actual operating state.
For example, the hot-film air mass meter indicates, in case of fouling, a measured value which is within the range of values but is nevertheless falsified.
- Does a "piece fault" (fault of a fixed value) exist?
In the event of a piece fault, the sender always sends the same measured value, despite changing operating states. This value is frequently within a valid range of values, hence the fault is difficult to diagnose.
- Does a "signal range fault" exist?
If a sender sends a measured value which is not within the valid sender-specific range of values, this means that a signal range fault has occurred.



The engine speed sender G28

The engine speed sender is seated in the crankshaft flange. A Hall sender is integrated in the engine speed sender. The sender registers the engine speed using the sender wheel on the crankshaft.

The engine speed is utilised for several calculations within the control unit.

For example:

- calculation of injection quantity and commencement of injection
- cylinder-selective misfire detection
- charge pressure control

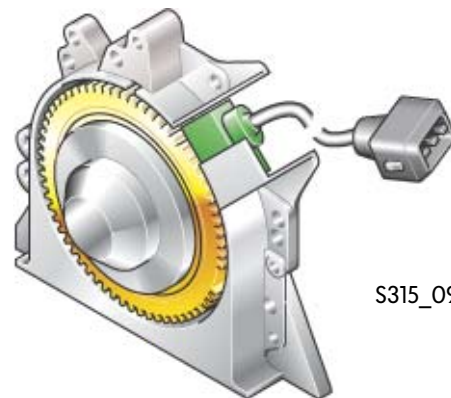

S315_091

EOBD routine

The coolant temperature sender G62

The plausibility check on the measured values of the sender covers the warm-up period within a predefined time scale. The signal from the sender is plausible if it indicates that the coolant temperature has reached a defined threshold or has completed a defined rise within a period dependent on the starting temperature. The diagrams below show the signal is plausibilised with the data used at the time.

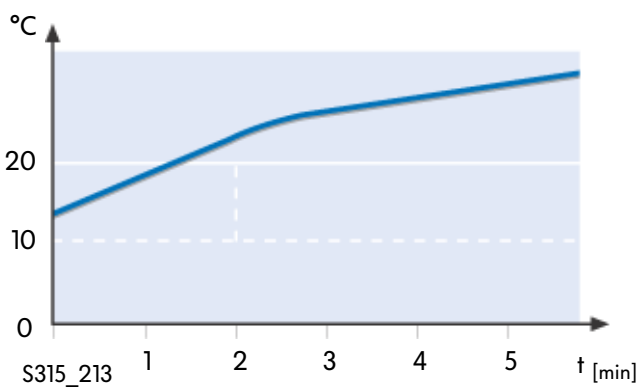

- Coolant temperature sender ok
In this case, the sender indicates plausible data: from a starting temperature of over 10°C, the temperature reaches a value of over 20°C within 2 minutes.

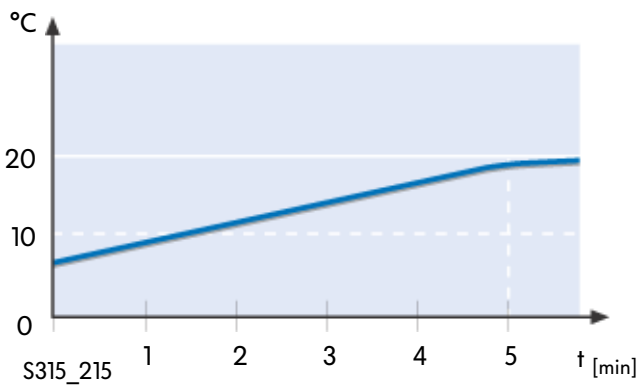

- Coolant temperature sender ok
In this case, the sender indicates within 5 minutes a rise in the coolant temperature of 10°C starting from a temperature of less than 10°C. Therefore, the measured values of the coolant temperature sender are plausible.

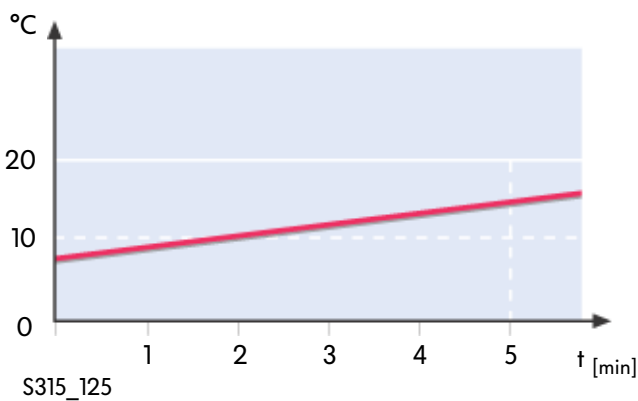

- Coolant temperature sender nok
In the adjacent diagram, the coolant temperature sender is defective: it indicates a temperature rise within 5 minutes which neither rises above the 20°C level nor rises by 10°C from a starting temperature of less than 10°C.

The charge air pressure sender G31

This sender is monitored in **TDI engines**.

The signals from the charge pressure sender are plausibilised after turning on the ignition and before starting the engine.

The measured value of the ambient air pressure sender is utilised as a comparison value for the measured values of the charge pressure sender. The comparison of these two measured values results in a pressure difference whose average value must not exceed a defined threshold.

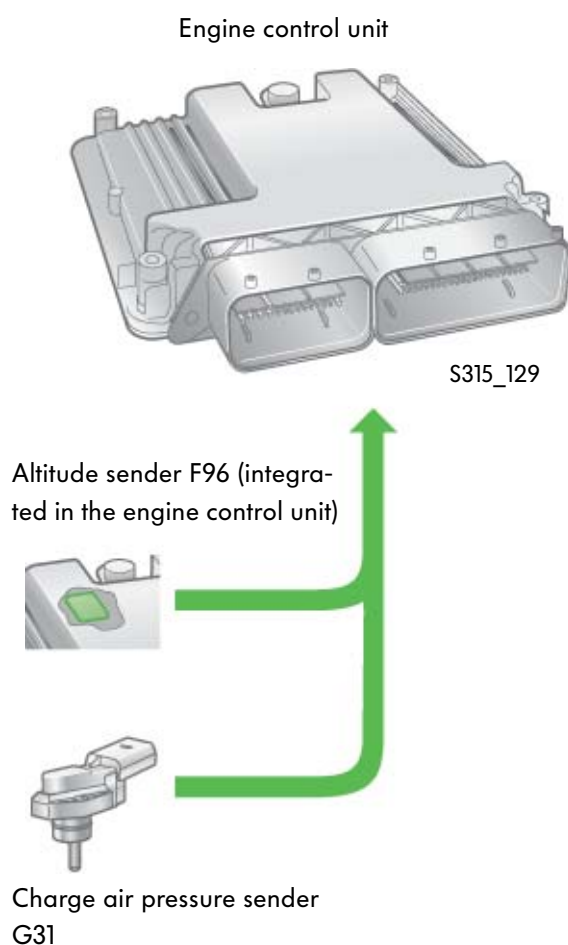

EOBD routine

The hot-film air mass meter G70

The hot-film air mass meter is fitted in **TDI engines**. A new feature is the inner tube, which protects the sensor against fouling and concentrates the air streaming past the sensor.

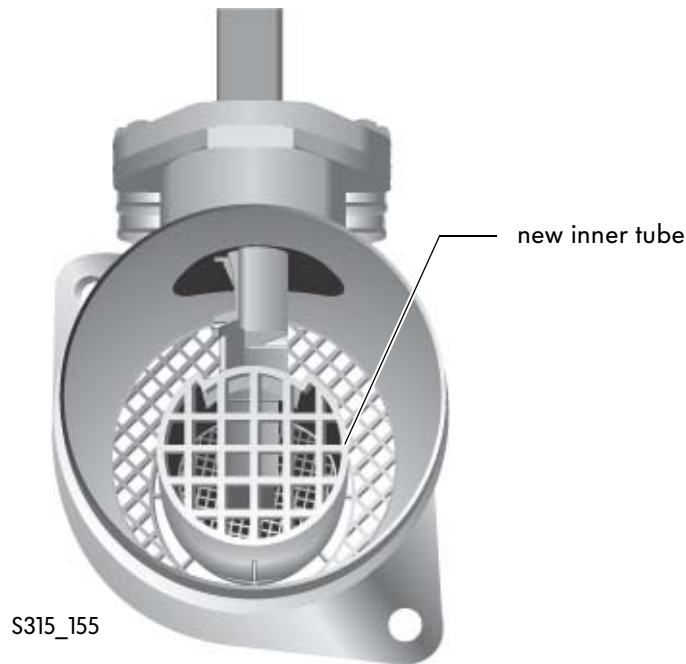

The plausibilisation of the hot-film air mass meter allows the following faults to be detected :

- Leak in intake duct.
- The hot-film air mass meter is fouled and indicates plausible measured values as a function of air mass. However, these measured values do not represent the actual operating states.
- The EGR valve is stuck in the open position.
- The charge air cooler is defective.

The engine control unit calculated a nominal air mass from the measured values for speed, charge pressure and charge air temperature. The air mass measured by the air mass meter is compared to the calculated value. This comparison produces a ratio. If this ratio exceeds a threshold value for a defined period, a fault is detected.

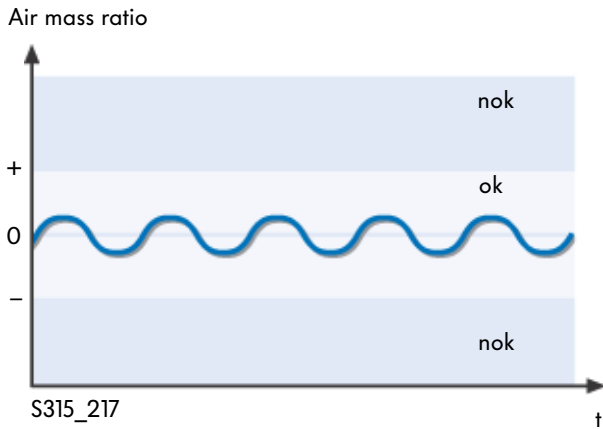

- Hot-film air mass meter ok
In this case, the calculated air mass to measured air mass ratio swings about the zero point. The measured values of the hot-film air mass meter are plausible.

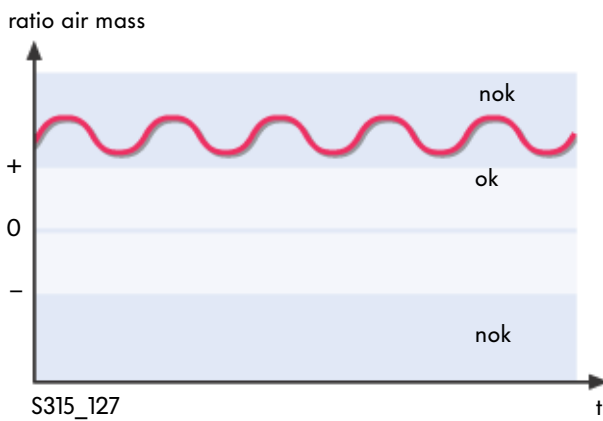

- Hot-film air mass meter nok
In this case, the hot-film air mass meter is defective: the ratio is above of the ok range over a lengthy period.

EOBD routine

The fuel temperature sender G81

This sender is only monitored for **unit injector engines**.

The sender must indicate a specific fuel temperature rise within a predefined operating time of the engine or a driving cycle. The signal is currently plausibilised with the following data, which the sender must indicate:

- The fuel temperature must either rise above an idling speed of 30°C in 10 operating hours or
- rise by 10°C within a single driving cycle.

- The driving cycle
A driving cycle can be described with "Ignition on, generate speed, ignition off". For definition purposes, it is irrelevant what distances are covered and under what operating conditions. In addition to the general definition, there are also standardised driving cycles, such as the NEDC for checking the exhaust emissions of a vehicle.



It is necessary to monitor the fuel temperature because the fuel viscosity, and hence the injection quantity, changes with rising temperature. The engine control unit makes allowance for the viscosity by adapting the opening times of the injectors.

- Fuel temperature sender ok
In the adjacent case, the sender indicates a fuel temperature rise of over 30°C in 10 operating hours. Therefore, the signal from the fuel temperature sender is plausible.

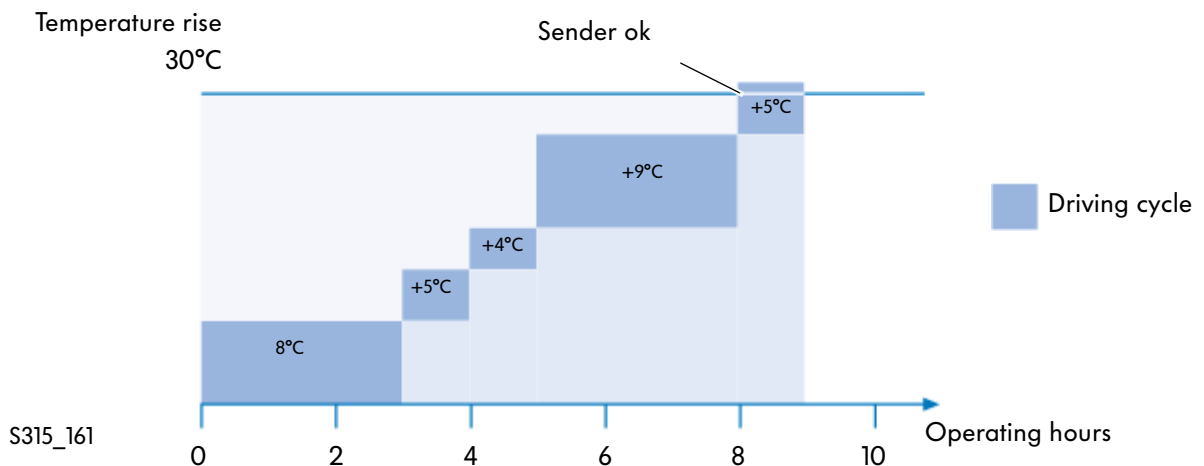

- Fuel temperature sender ok

In this case, the signal from the fuel temperature sender is plausibilised after only 5 operating hours, because a temperature rise of over 10°C is indicated within a single driving cycle.

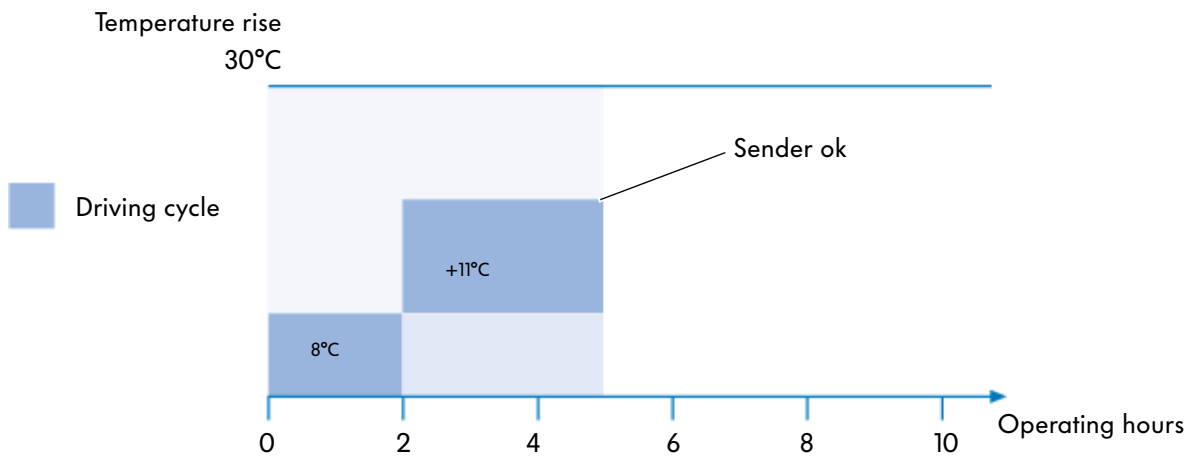

S315_173

- Fuel temperature sender nok

In this case, the fuel temperature sender is defective: a temperature rise of over 10°C is not indicated in any driving cycle, and the indicated temperature rise after 10 operating hours is less than 30°C.

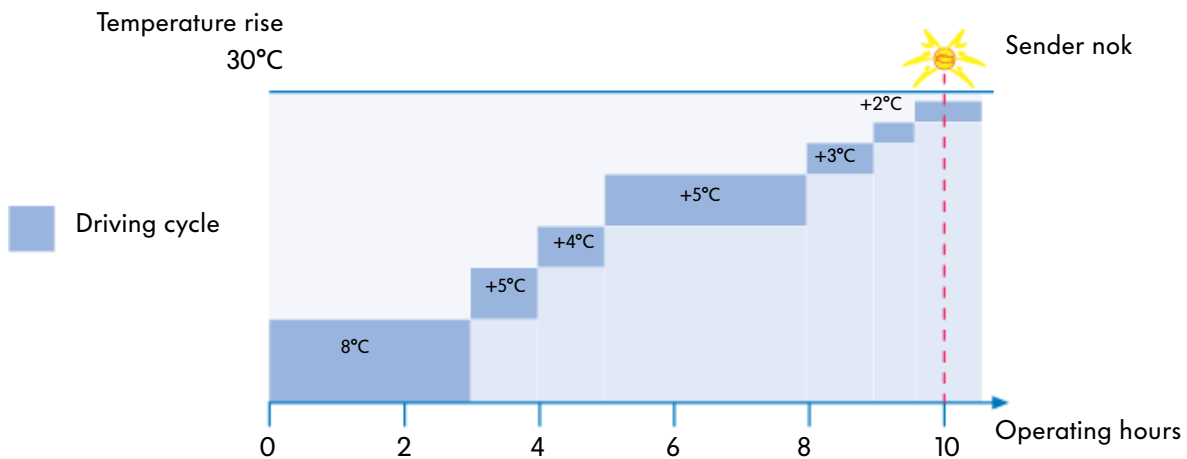

S315_175



EOBD routine

The needle lift sender G80

The needle lift sender is only fitted in **engines with a distributor type injection pump**. Firstly, the sender voltage signal of the needle lift sender is monitored. Secondly, the measured values of the sender are plausibilised. At the same time, it is checked whether the signal from the needle lift sender exceeds a defined maximum threshold. A fault is detected if the signal deviates from the measured value of the engine speed sender within a defined diagnosis window.

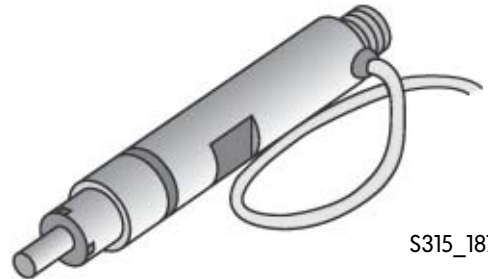

S315_187

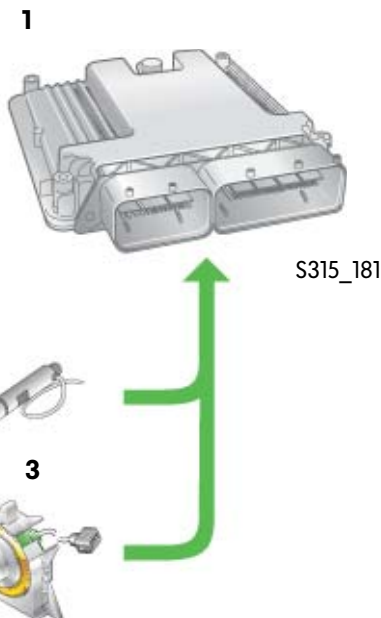

S315_181

The signal of the engine speed sender is utilised to plausibilise the signal from the needle lift sender.

- 1 Engine control unit
- 2 Needle lift sender G80
- 3 Engine speed sender G28

The lambda probe G39

Lambda probes are currently fitted only in diesel engines in combination with a **particle filter system**. The oxygen concentration measured by the lambda probe is plausibilised at two operating points. At part throttle, the signal is compared to an oxygen concentration calculated from the injection quantity and air mass. In overrun, the signal is compared to the oxygen content of 21%. If large deviation occurs between the values at one of the operating points, a fault is registered and the MIL is activated.



Part throttle

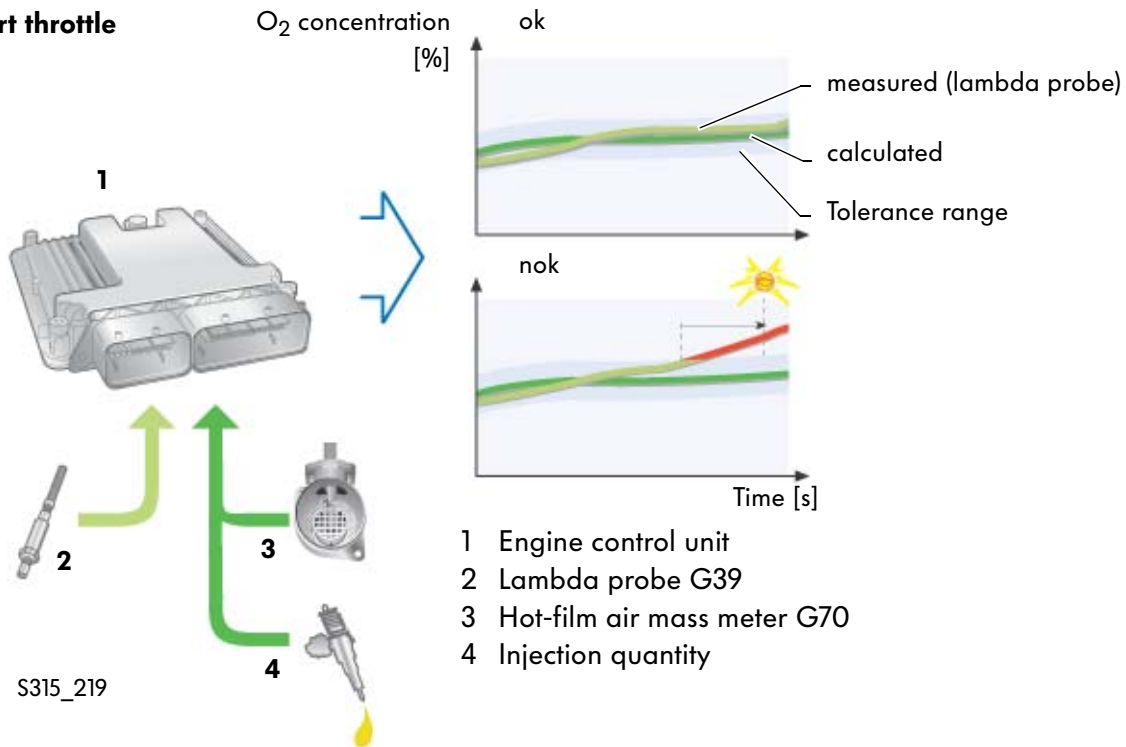

Overrun

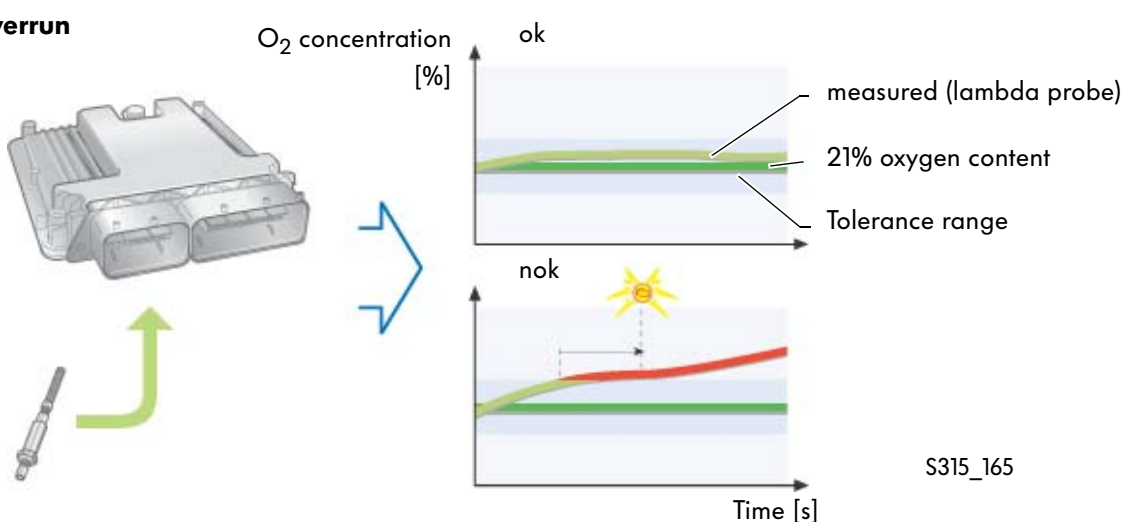

EOBD routine

The road speed signal

Depending on vehicle type and engine output, the road speed signal is provided either by the ABS control unit or by a road speed sensor. Control units and sensors are tested for electrical faults within the context of Comprehensive Components Monitoring.

The speed signal is plausibilised in two ways.



S315_010

1. If the speedometer indicates a value which is too high (e.g. more than 250 kph), a fault is registered and the MIL is activated.

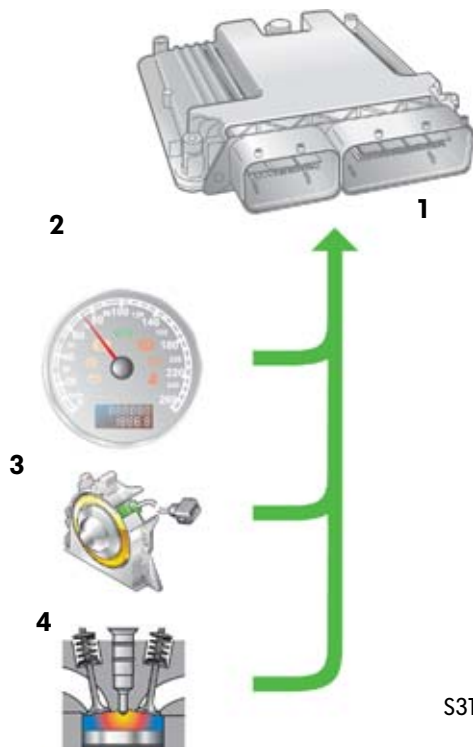

S315_089

2. The road speed signal is compared to the current measured injection quantity and the engine speed. Based on defined parameters, the control unit can determine whether the road speed signal is plausible in relation to the other data.

- 1 Engine control unit
- 2 Road speed signal
- 3 Engine speed sender G28
- 4 Injection quantity

Working with EOBD

In the context of EOBD, all components relevant to exhaust emissions are subject to continuous monitoring by EOBD routines. They ensure that faults relevant to exhaust emissions are detected, indicated to the driver and stored in the fault memory.

If a fault is indicated to the driver by the illuminated MIL, the driver is obliged to have the complete EOBD system of his vehicle checked by a workshop. In this case, a defined procedure must be carried out as shown on the next pages.



Service

EOBD flowchart

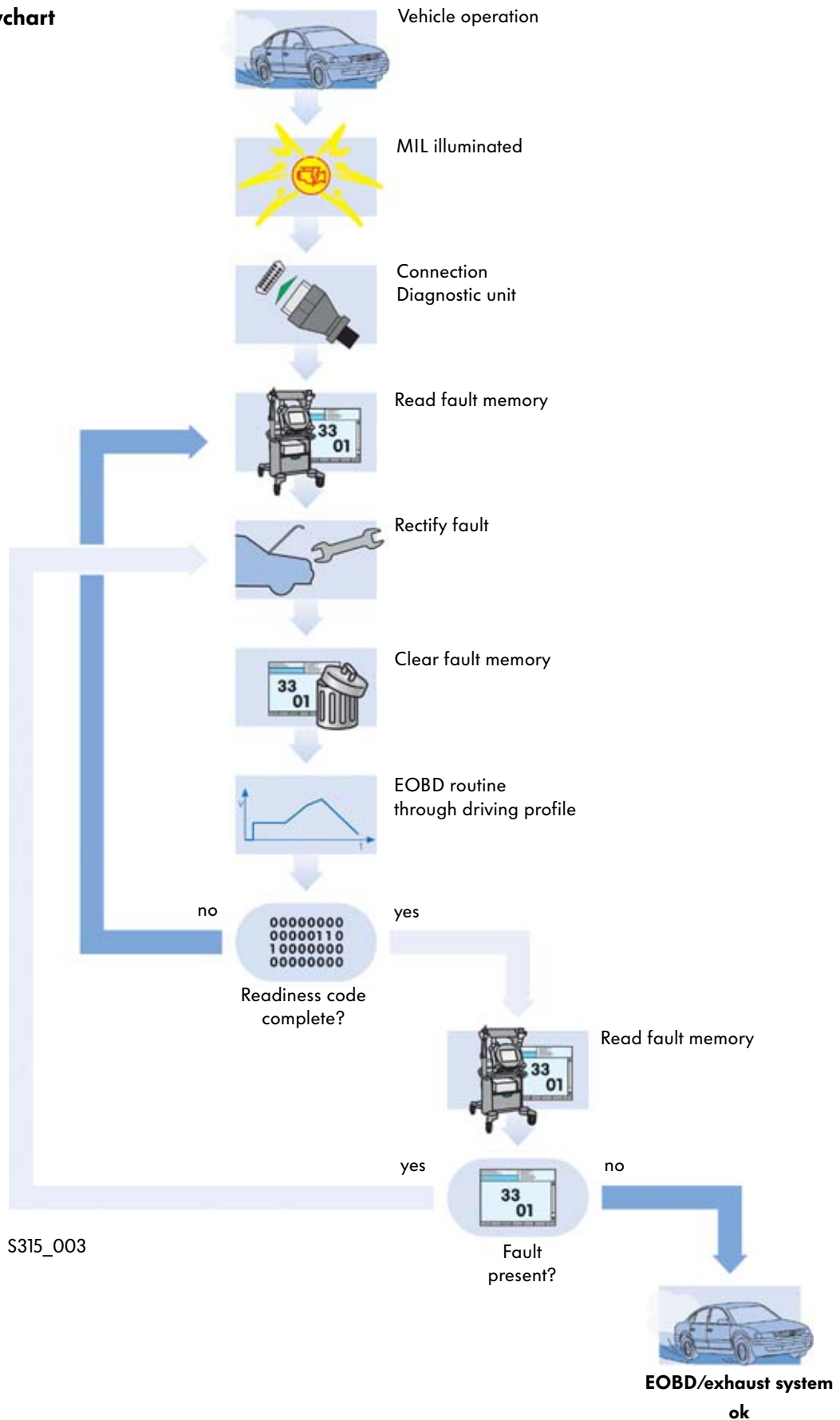

S315_003



The exhaust emissions warning lamp K83 (MIL)

Faults which have a strong influence on exhaust emissions are indicated by the exhaust emissions warning lamp K83 (MIL).

When the ignition is turned on, the MIL must be activated by way of a performance check. After the engine is started, the MIL goes out as long as no fault is registered. If faults relevant to exhaust emissions are detected in three successive driving cycles, the MIL will be continuously lit.

When the MIL is lit, the driver is obliged to have his vehicle checked at a workshop. The distance covered with the MIL lit is therefore determined by a kilometre/mileage counter.

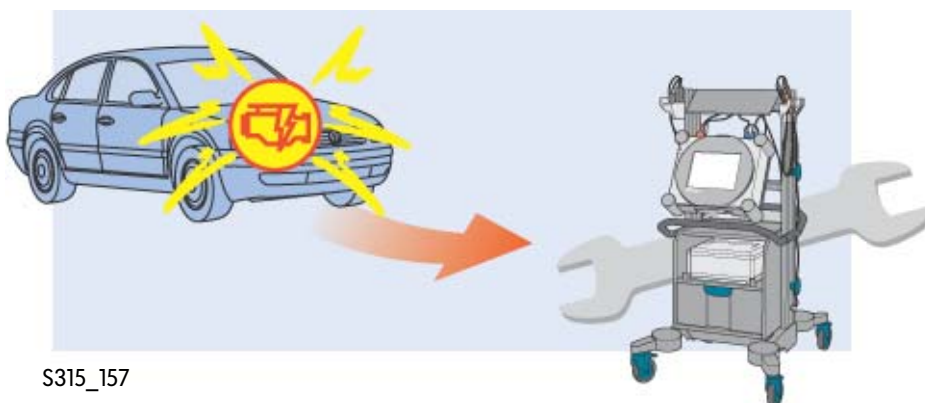

Service

The entries in the fault memory

The MIL is activated if an EOBD routine detects the same fault relevant to exhaust emissions two or three times in succession during vehicle operation. If this fault is not detected again by the diagnosis system for four times in succession, the lamp will be deactivated again. However, the fault remains registered in the fault memory of the engine control unit.

If the fault does not occur again within 40 WUC (Warm Up Cycles), the fault code, kilometre/mileage counter and FREEZE FRAME (fault peripheral data, see glossary) will be cleared again.

The kilometre/mileage counter determines the distance covered with the MIL lit. It is reset to "0" when

- the fault memory is cleared after the fault has been remedied,
- a fault has not occurred again within 40 WUCs, and therefore the fault code is deleted or
- the lit MIL is deactivated after four fault-free diagnosis cycles and reactivated if a fault occurs again. The kilometre/mileage counter starts counting at "0".



The WUC (Warm Up Cycle) is a driving cycle in which the engine temperature has risen by at least 23°C and reached at least 70°C.

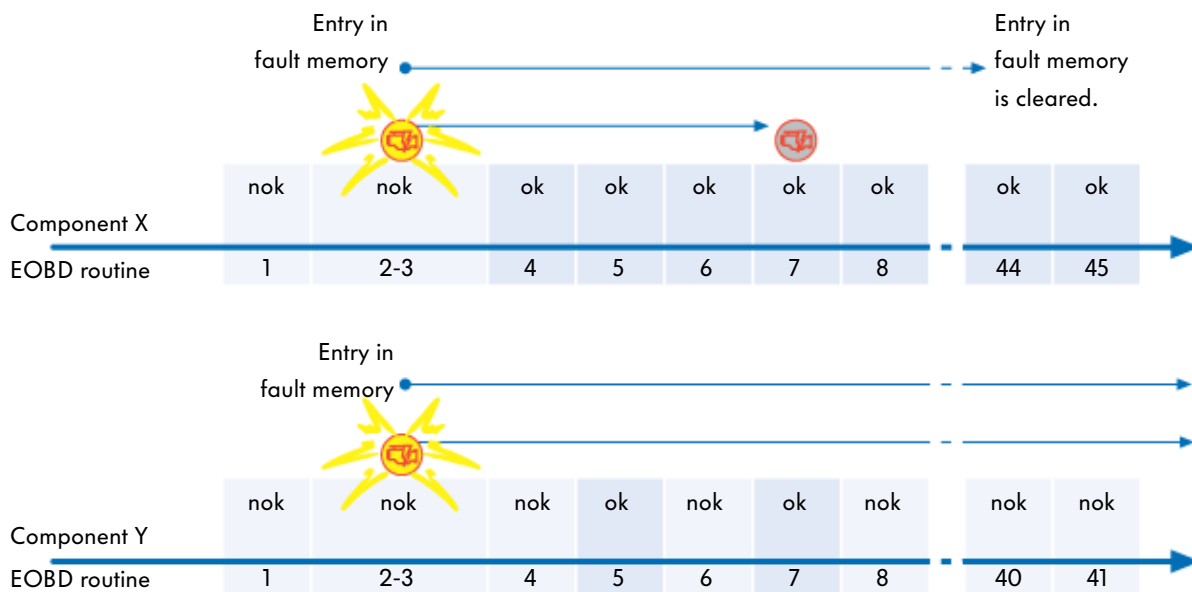

S315_049

The readiness code

In the context of EOBD, all components relevant to exhaust emissions are continuously checked for correct function by diagnosis routines. The so-called readiness code is set so that a check function can determine whether these diagnosis routines have actually been carried out.

The readiness code must be generated by the engine control unit during vehicle operation if:

- the readiness code is deleted by a fault memory reset or
- the engine control unit is put into operation for the first time.

The readiness code consists of a multi-digit number code and indicates whether all diagnosis routines which are relevant to exhaust emissions, and for which the relevant systems are available, have been run by the engine management system. Each digit stands for a specific system or the associated diagnosis routine.

The code does not indicate whether a fault is present in the system, rather it only states whether the relevant diagnosis routine has been completed (BIT to 0) or has still not been carried out or has been cancelled (BIT to 1).

The readiness code is generated if all diagnosis routines (in some cases, multiple diagnosis routines) have been completed. It is set irrespective of the result of a diagnosis (OK/not OK).



Not all diagnosis routines mentioned are required to be included in the readiness code by law. If faults are detected in diagnosis routines not contained in the readiness code, an entry is made in the fault memory.



A vehicle may only be handed over to the customer with the readiness code set.



Service

Read readiness code

There are two ways to read the readiness code.

- with any GENERIC SCAN TOOL (OBD visual display unit) or
- with the VAS 5051 or VAS 5052 vehicle diagnosis, testing and information system.
To this effect, the engine control unit is to be selected with address word "01", and the functions "08 Read measured value block" and "Measured value block 17" are invoked.

The VAS 5051 diagnostic unit also allows the readiness code to be read in GENERIC SCAN TOOL Mode. To this effect, enter the operating mode "Vehicle self-diagnosis", select the GENERIC SCAN TOOL Mode with address word "33" and "Read current engine operating data" under Mode 1. The readiness code will then be output under "PID01" (by analogy with measured value block 17).

The readiness code consists of 4 BYTES each with 8 BITS and is represented in measured value block 17 as a sequence of 0s and 1s. The BITS of BYTE 0 indicate the status of the MIL and the number of entries in the fault memory. The BITS of BYTE 1 - 3 either stand for:

- the availability of an inboard system,
- the diagnosis status of a system (diagnosis bit) or
- are unassigned.

This code is generically standardised, and therefore not every BIT is assigned. Unassigned BITS are set to 0 for the vehicle in question.

Bit:	7	6	5	4	3	2	1	0	
Byte:	7	6	5	4	3	2	1	0	
0	0	0	0	0	0	0	0	0	Readiness code is complete
1	0	0	0	0	0	1	1	0	
2	1	0	0	0	0	0	0	0	
3	0	0	0	0	0	0	0	0	

Bit:	7	6	5	4	3	2	1	0	
Byte:	7	6	5	4	3	2	1	0	
0	0	0	0	0	0	0	0	0	Readiness code is incomplete
1	0	1	1	0	0	1	1	0	
2	1	0	0	0	0	0	0	0	
3	1	0	0	0	0	0	0	0	

Byte 0 indicates the status of the MIL and the number of entries in the fault memory.

Digits unassigned

System checks:
1 = diagnosis not completed
0 = diagnosis completed

System available:
1 = is supported
0 = unavailable



BITS which denote a system can have a value of "1" when the readiness code is completely set. The "1" denotes "System available". All other BITS must be set to "0".



The bit assignments of the readiness code

The following list shows the assignments of BITS of the readiness code to systems and diagnosis routines. As in the previous illustration, the BITS which denote the availability of a system are shown against a dark background. The fields shown against a red background stand for the associated diagnosis routines. Generally, it is possible for further digits to be assigned in the future.

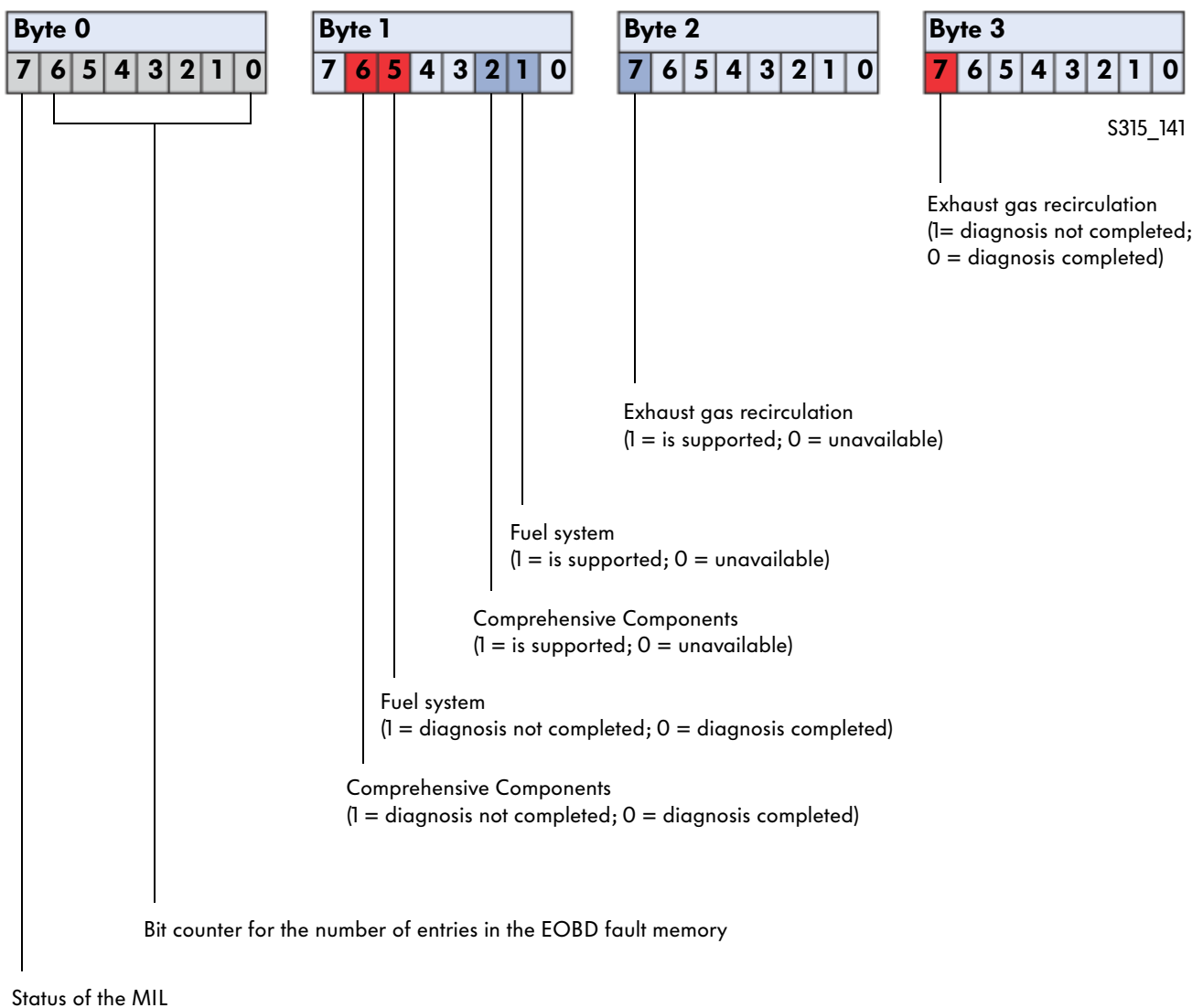

When setting the readiness code, attention must be paid to what BITS are allowed to be set to 1 and what BITS must be set to 0.



Service

Rectify fault and generate readiness code

After all faults have been rectified and the fault memory has been cleared, the readiness code must be generated again. This can be achieved firstly by running the NEDC several times on the rolling road. In practice, however, a certain DRIVING PROFILE is run for diesel engines with EOBD in order to ensure that all EOBD routines have been completed. The DRIVING PROFILE does not require a rolling road, and is less complicated than the NEDC.

Most diagnosis routines relevant to EOBD are activated in idling mode directly after the engine is started. To enable the diagnosis routines to be carried out completely, however, the following DRIVING PROFILE must be run:

- 5 seconds ignition OFF.
- 5 seconds wait between Ignition ON and engine start.
- 42 kph in 3rd gear for 20 seconds.
- Starting in overrun, acceleration at full throttle in 3rd gear up to 3500 rpm.
- Unbraked overrun phase in 5th gear from 2800 rpm to 1200 rpm.

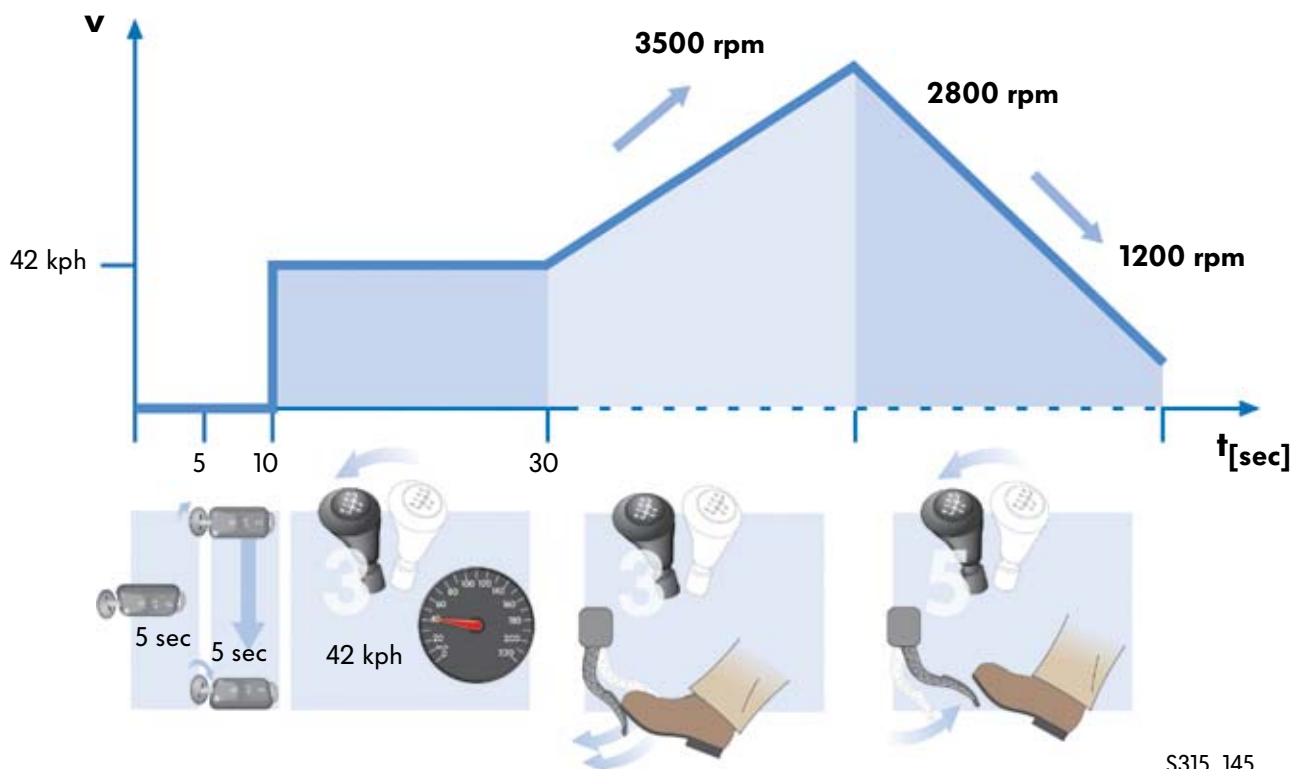

S315_145



At present, the DRIVING PROFILE or the NEDC have to be run three times in order to generate the readiness code. In future, the relevant BIT will be set to 0 after the first cycle of the DRIVING PROFILE (without fault memory entry) or after the third cycle. Ideally, this would mean that the profile has to be run once only if all diagnosis routines are completed during the first cycle.

If the readiness code is not completely set to 0 upon completion of several diagnosis routines, this means there is a fault in the diagnostic system. In this case, the fault must be located with the fault-finding functions of the VAS 5051 and remedied. After that, the fault memory must be reset and the readiness code generated again.



As not all diagnosis routines are available in all vehicles, the unused digits of the readiness code are generally set to "0".



Service

The Generic Scan Tool (OBD visual display unit)

According to EOBD guidelines, faults relevant to exhaust emissions and the data acquired by the engine control unit within the EOBD must be readable using any OBD display terminal. Therefore, these faults are standardised and defined in a specific code. This code is known as the SAE code. SAE stands for the "Society of Automotive engineers" - the institution by whom the codes were established. The SAE code is utilised by all OBD systems.

The SAE codes comprise a "P" (for "Powertrain") followed by four digits. The first digit identifies the two higher-order fault groups POxxx and P1xxx.

POxxx: the so-called "P zero" codes are fault codes defined by the SAE. They are generic and have standardised fault texts.

P1xxx: this fault group contains codes defined by automobile manufacturers which have to be reported to the authorities. They have different meanings depending on manufacturer. The third digit indicates the assembly in which the fault has occurred. The fourth and fifth digits identify the components and / or systems in which the fault has emerged.



It is possible for the same fault to be stored as a P0 code in the GENERIC SCAN TOOL and as a P1 code in the VAS 5051 or VAS 5052. If the P1 code describes the fault in greater detail (as it is manufacturer-specific), it may be different to the P0 code.

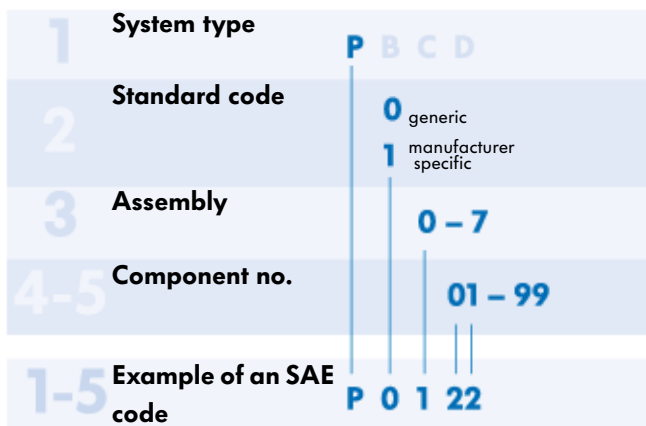

There also exist P2xxx- and P3xxx codes. P2 codes are standardised by the SAE (as with P0 codes). P3 codes can be standardised or manufacturer-specific.

S315_159

Read EOBD fault memory

The following steps are necessary to read the EOBD fault memory:

If you are using the VAS 5051 or VAS 5052 vehicle diagnosis, testing and information system, change over to the EOBD fault memory with "Address 33".

- "Mode 3" Read and print fault memory
- "Mode 2" Read FREEZE FRAME. FREEZE FRAME stands for the engine peripheral data and operating conditions existing at the time of fault entry. Print out the result.
- "Mode 7" Read "pre-memory" in which the faults are stored before they are indicated by the MIL and stored in the fault memory.
- "Mode 4" Clear diagnosis data. Note: do not carry out this step until all other steps have been documented! The fault memory of the VAS 5051 or VAS 5052 will also be cleared.
- "Mode 3" Read and print out fault memory again to make sure that all faults have been cleared
- "Mode 1" Read and print out current diagnosis data.

The routine specified here is that of the VAS 5051. Basically, the routine for reading out the EOBD fault memory is the same for all GENERIC SCAN TOOLS.

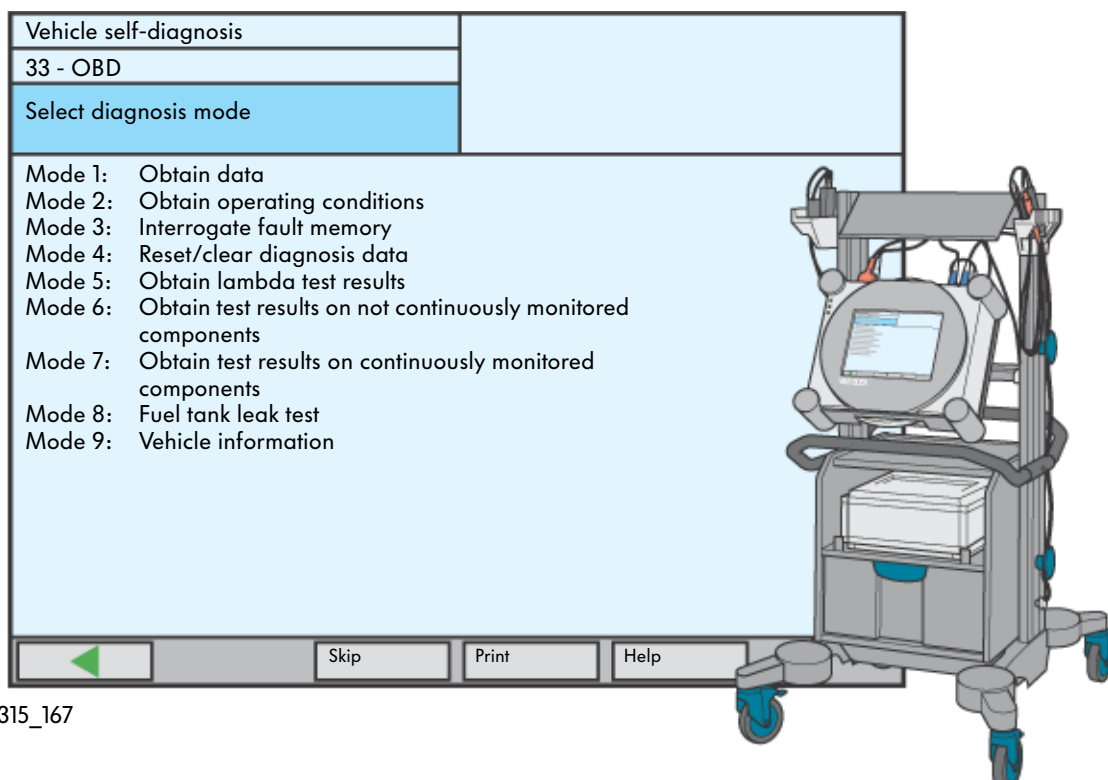

S315_167



Service

Diagnosis plug T16

The individual terminals of the diagnosis plug are standardised.
The pins are assigned as follows:

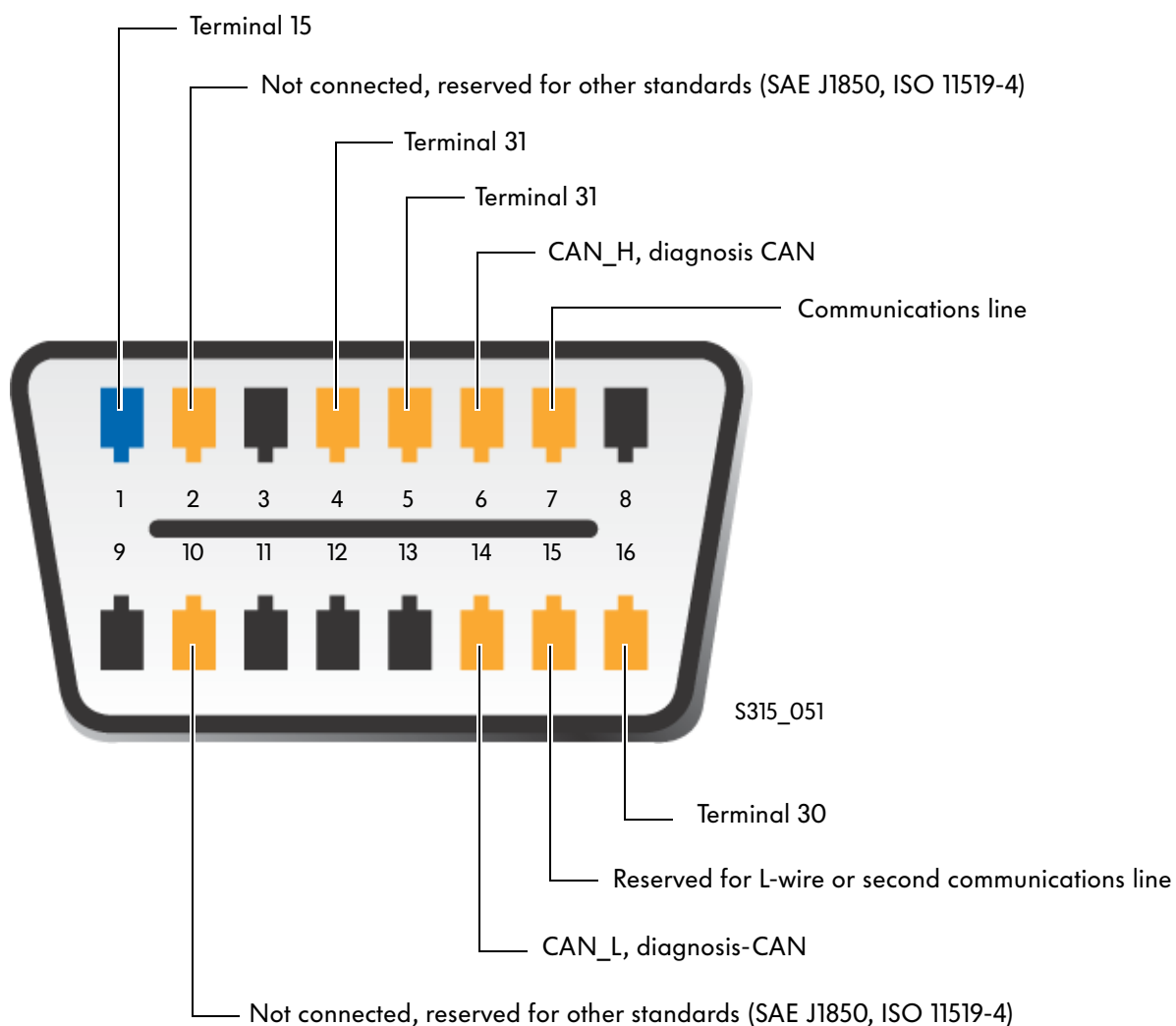

Connected in standard configuration at Volkswagen.



Pin function is defined by ISO standard.



Pin is not connected, can in future be enabled by the vehicle manufacturer for group vehicles as required.

Ash

Collective term for the substances left over after combustion. (cf. "SOOT")

Bit

Shortened form of the expression "binary digit". A BIT denotes a unit of information, e.g. "off"/"on" or "0"/"1".

Byte

A BYTE is a combination of 8 BITS. It is a made-up word derived from the word "BIT".

Driving profile

Operation of a vehicle in accordance with certain specifications in such a way that different operating states are obtained. To set the readiness code in diesel vehicles, for example, it is necessary to run a defined DRIVING PROFILE.

Freeze Frame

Fault peripheral data: record of the operating data and states existing at the time of occurrence of a fault.

Generic Scan Tool

(OBD display terminal)

All faults relevant to exhaust emissions which have been detected by the EOBD must be readable with any OBD display terminal via the diagnosis interface. The use of OBD display terminals for spot checks is also planned.

NEDC

New European Driving Cycle, standardised driving cycle for determining the exhaust emissions of motor vehicles.

Soot

Consists of carbon which builds up around a condensation core during the formation of SOOT. (cf. ASH)



Test yourself

1. Please complete the following sentences:

- a New diesel-powered passenger car models (e.g. Touran, Golf 5) will only be eligible for homologation with effect from if they are equipped with EOBD.
- b Production diesel-powered vehicles which have been on the market for longer, are required to be equipped with EOBD as of

2. What is the principal purpose of the NEDC?

- a To generate the readiness code.
- b To determine the exhaust emissions during homologation of a vehicle.
- c To test the exhaust emissions at the workshop.

3. Which statement is true?

- a An electrical EGR valve will be used in some diesel engines.
- b In several diesel engines, the EGR valve is pneumatically activated.

4. What happens when the particle filter is becoming clogged?

- a A lamp in the dash panel insert signals to the driver that the particle filter is becoming clogged. He must have the filter replaced at a workshop.
- b A lamp in the dash panel insert signals to the driver that the particle filter is becoming clogged. He must have the filter cleaned at a workshop.
- c The filter cleans itself by burning off the soot particles during vehicle operation.



5. The differential pressure sensor is connected to exhaust system by branch exhaust pipes before and after the particle filter. Which of the following statements is true?

- a From the pressure difference, the control unit detects an increasing amount of soot which can cause clogging of the particle filter.
- b From the pressure difference, the control unit can determine whether it is necessary to initiate a regeneration cycle.
- c From the pressure difference, the control unit can determine whether it is necessary to replace the exhaust system.

6. What is a Freeze Frame?

7. Which statement is true?

- a The readiness code is set when all diagnosis routines relevant to exhaust emissions have been completed by the engine management system. It indicates whether respective diagnosis routines have been completed.
- b The readiness code is set when all diagnosis routines relevant to exhaust emissions have been completed by the engine management system. It indicates whether there are any faults in the system.
- c The readiness code must be reset if components relevant to exhaust emissions have been replaced.



Notes

Answers:

1. a: 2003, b: 2004

2. b

3. a, b

4. c

5. a, b

6. Fault peripheral data which describe the state of the engine at the time of occurrence of the fault and help to locate the source of the fault.

7. a, c





EOBD



© VOLKSWAGEN AG, Wolfsburg, VK-36 Service Training

All rights and the right to make technical alterations reserved

000.2811.36.20 Technical status 06/03

♻️ This paper was manufactured from pulp that was bleached without the use of chlorine.